

LINEAR MOTOR CATALOG

IRIS

Short Stroke Motors

TABLE OF CONTENTS

- A Passion for Technology 3
- Overview 4
- Iris Line 6
 - Features 7
 - S/M/L Performance Specifications 8
 - S-05 Mechanical Specifications 9
 - S-10 Mechanical Specifications 10
 - M-12 Mechanical Specifications 11
 - L-16 Mechanical Specifications 12
- Definitions 13
- Contact 15

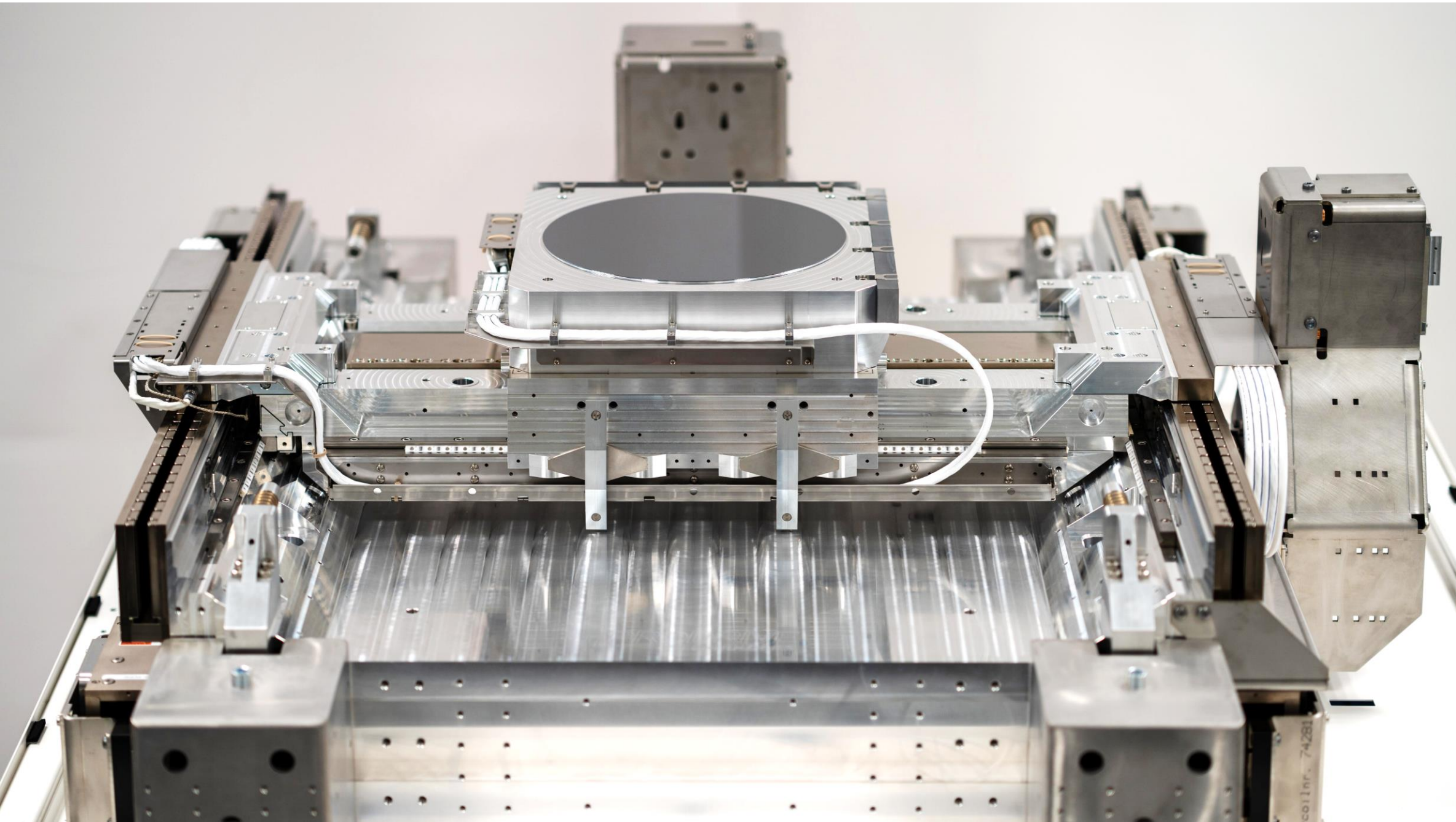

Linear motors integrated in a motion stage

Knowledge

Engineering excellence is the driving force behind linear motor innovation in both design and manufacturing. Prodrive has a highly skilled group of (electro-)mechanical engineers capable of customizing linear motor technology towards your needs.

Quality

Quality is in the DNA of Prodrive Technologies. With a long history in electronics manufacturing, Prodrive continues in the area of linear motor manufacturing with the same philosophy and processes, setting a new standard within the linear motor market.

Automation

Design for manufacturing is key to reduce cost and guarantee quality. Winding, assembly, vacuum potting and magnet gluing are highly automated processes which guarantees a constant quality at minimum cost.

Time to market

Due to the agility of Prodrive Technologies' large development department, customization can be performed in a very short time, providing a short time to market for challenging mechatronic applications.



Prodrive Technologies HQ Campus, The Netherlands

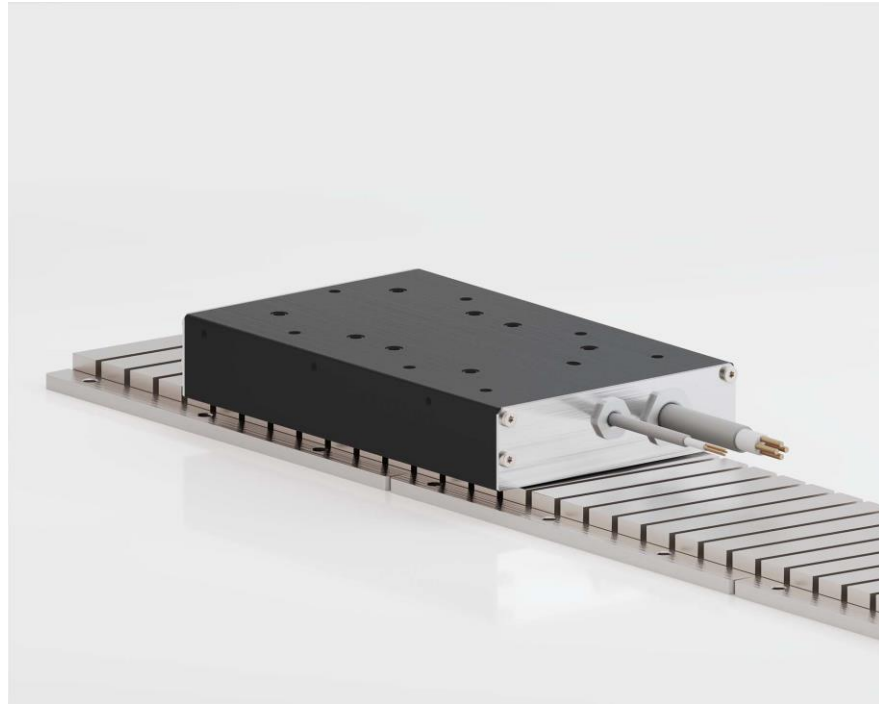

Chiron

The Chiron line offers iron core linear motors which are optimized for high force and high efficiency. Find the optimal fit for your application due to the many different available form factors.

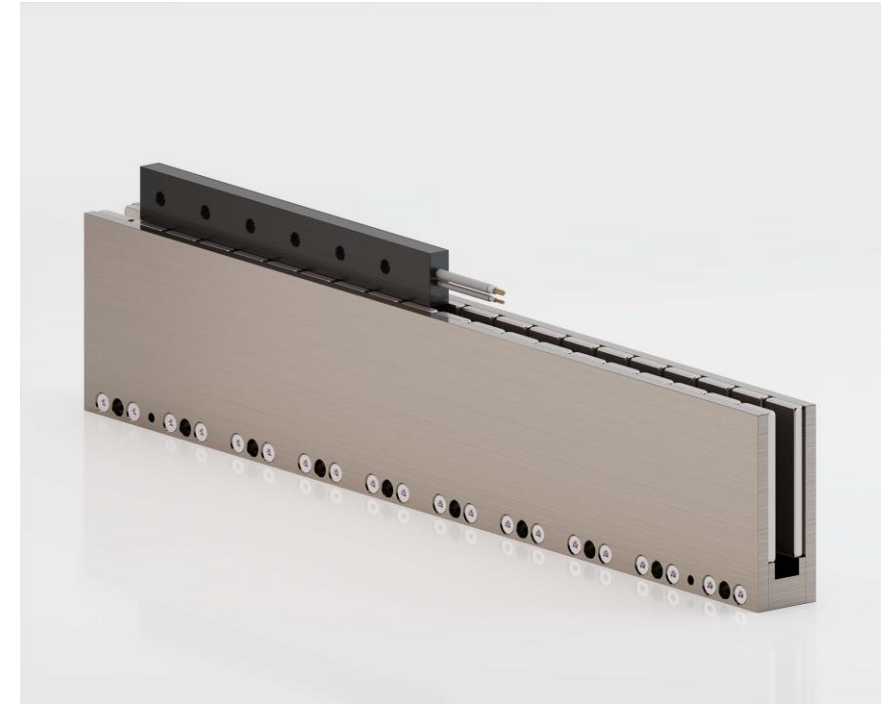

Phoenix

The Phoenix line offers ironless linear motors, for applications requiring an extremely low force ripple for excellent servo performance without attraction forces. Available in a large range of sizes.



Gryphon

The Gryphon line offers a cost-effective solution for vacuum-compatible ironless linear motors. These motors also contain features providing magnetic shielding.

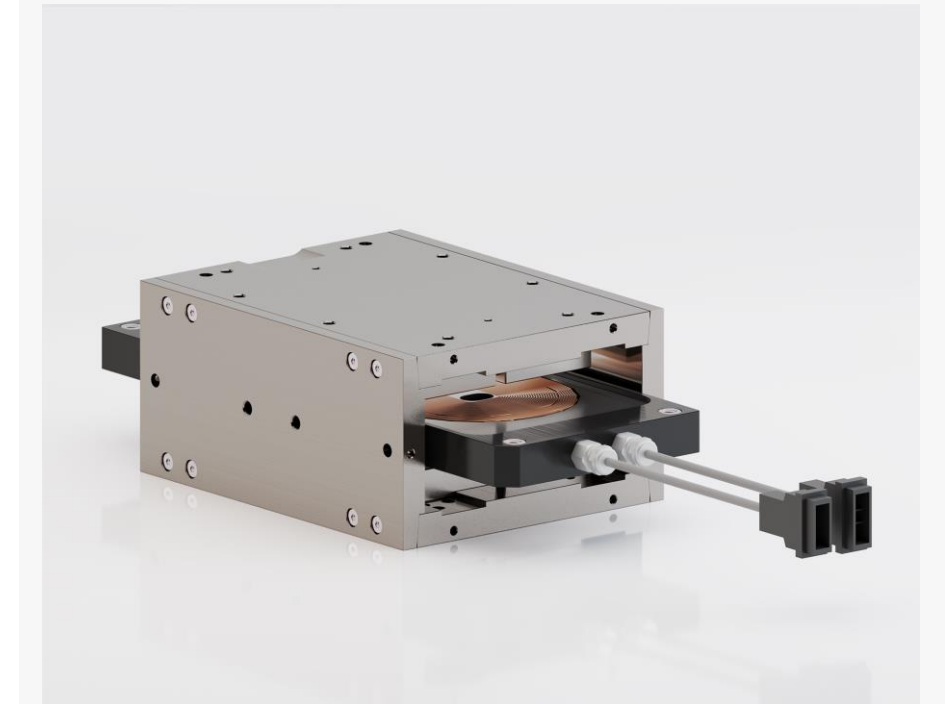

Iris

For short stroke applications requiring a relatively large displacement in three directions, the Iris line provides a high force density with zero attraction forces in a rectangular form factor.

OVERVIEW

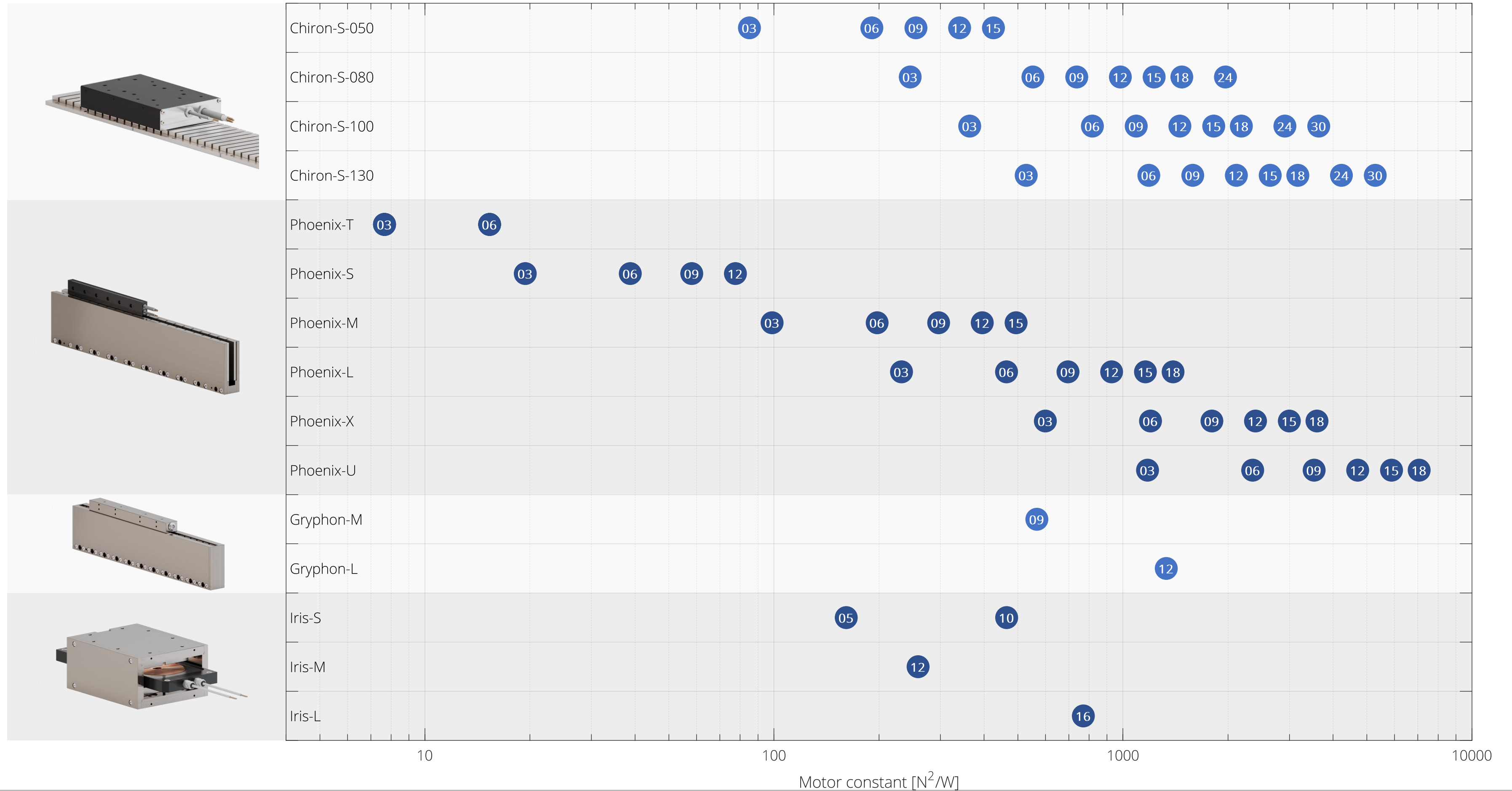

IRIS LINE

The Iris line offers short stroke linear motors with a rectangular form factor. The M and L size motors also contain magnetic shielding features.

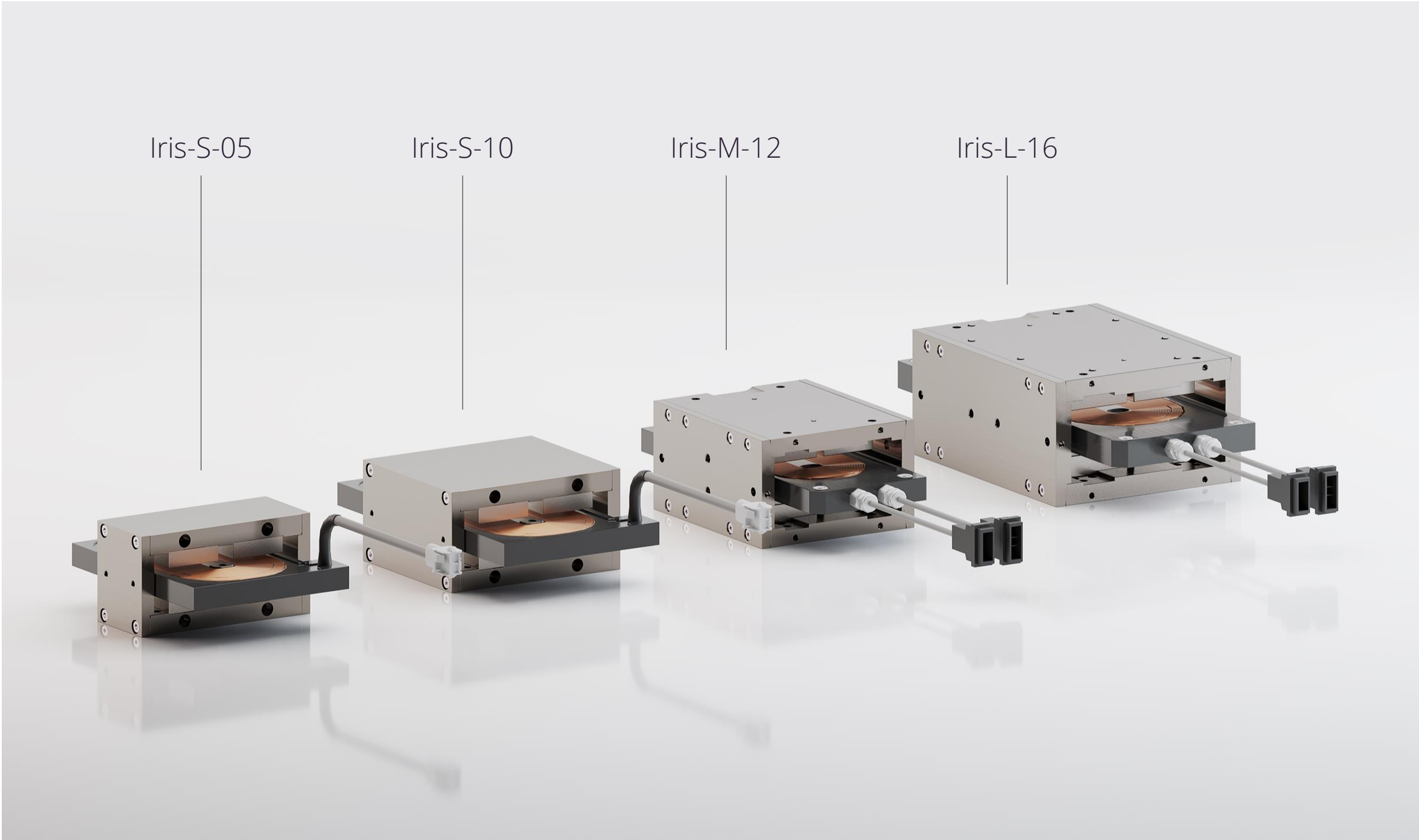

Iris line short stroke motors in different sizes

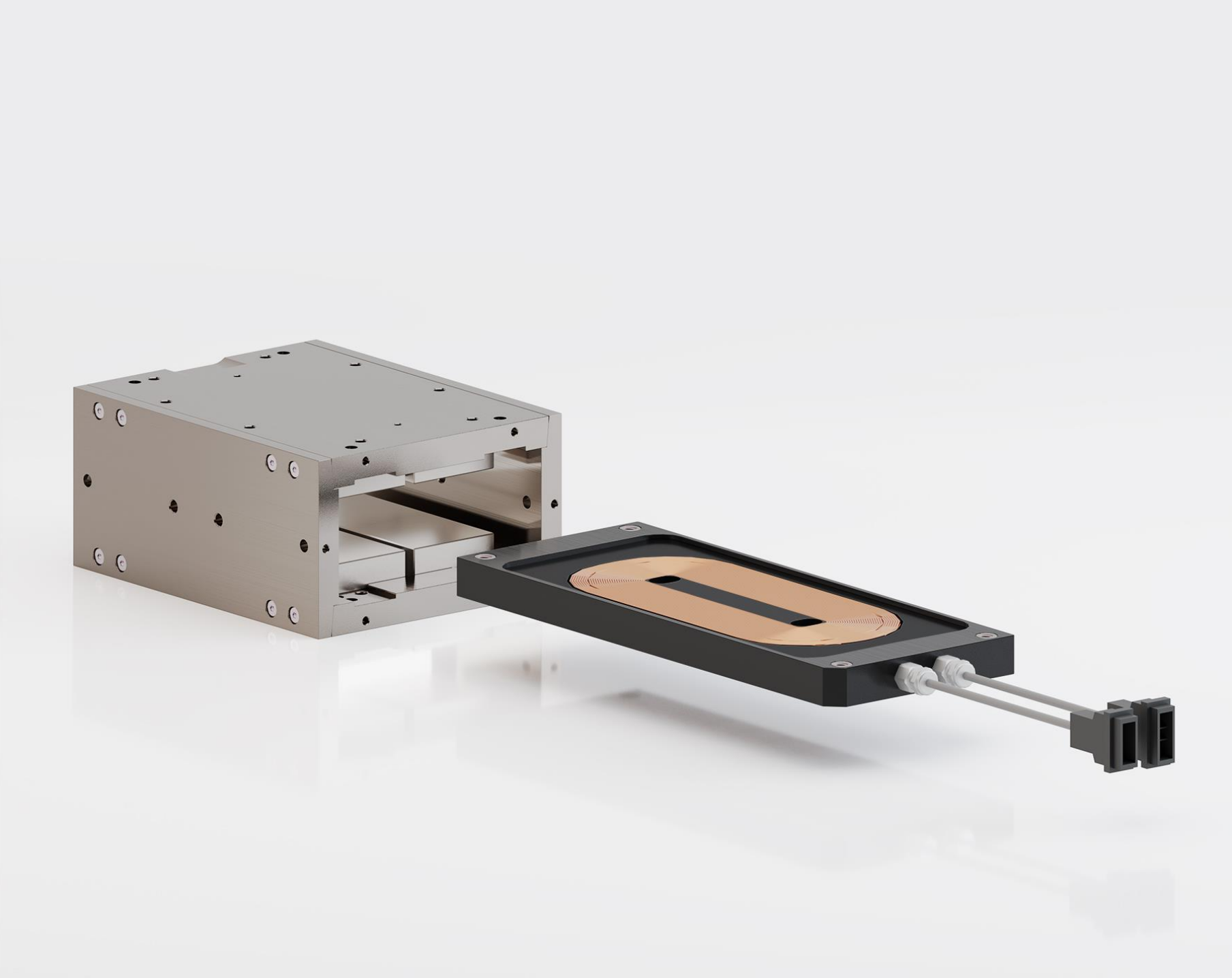

Iris-L-16

Iris-M-12

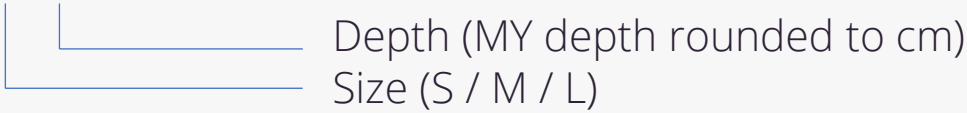

- Different sizes for optimal mechanical integration
- Coil unit housing optimized for heat transfer and force bandwidth
- Coil units are equipped with connectors
- IP rating of coil units is IP10
- The M/L size coil units have a temperature sensor (PT1000)
- The M/L size have magnets which are shorter than the back iron for improved magnetic shielding

IRIS PERFORMANCE SPECIFICATIONS

	Parameter	Symbol	Unit	T _{coil} (°C)	Iris-S-05	Iris-S-10	Iris-M-12	Iris-L-16
Electromech.	Peak force ($\alpha_T = 5^\circ\text{C/s}$ increase)	F _p	N	20	400	600	450	1150
	Continuous force	F _c	N	100	100	180	150	250
	Continuous force (UL rated)	F _c	N	20	n.a.	n.a.	80	170
	Attraction force (I = 0)	F _{att}	N	-	0	0	0	0
	Motor constant	S	N ² /W	20	161	464	259	770
	Force constant	K _f	N/A	-	23	47	19	48
Electrical	Maximum dc bus voltage	V _{dc}	V	-	60	60	100	100
	Phase resistance	R _{ph,20}	Ohm	20	3.4	4.7	1.4	3.0
	Phase inductance	L _{ph}	mH	-	16.0	25.9	4.7	15.5
	EMF constant	K _e	Vs/m	-	23	47	19	48
	Maximum rms current	I _p	A	20	17.6	12.8	24.3	24.5
	Continuous rms current	I _c	A	100	4.4	3.9	8.0	5.3
	Continuous rms current (UL rated)	I _c	A	100	n.a.	n.a.	4.3	3.6
Thermal	Continuous dissipation	P _{d,c}	W	100	88	94	120	110
	Continuous dissipation (UL rated)	P _{d,c}	W	100	n.a.	n.a.	34	51
	Thermal resistance, coils to interface	R _{thi}	K/W	-	0.91	0.85	0.67	0.73
	Thermal resistance, coils to conv. surface	R _{thc}	K/W	-	0.06	0.04	0.09	0.06
	Thermal time constant	τ _{th}	s	-	521	646	358	363

Notes

- Specifications are based upon a magnet temperature of 20°C
- See 'definitions' section at the end of the catalog for more details

Product marking / approvals (only for M/L size)



IRIS-S-05 MECHANICAL SPECIFICATIONS

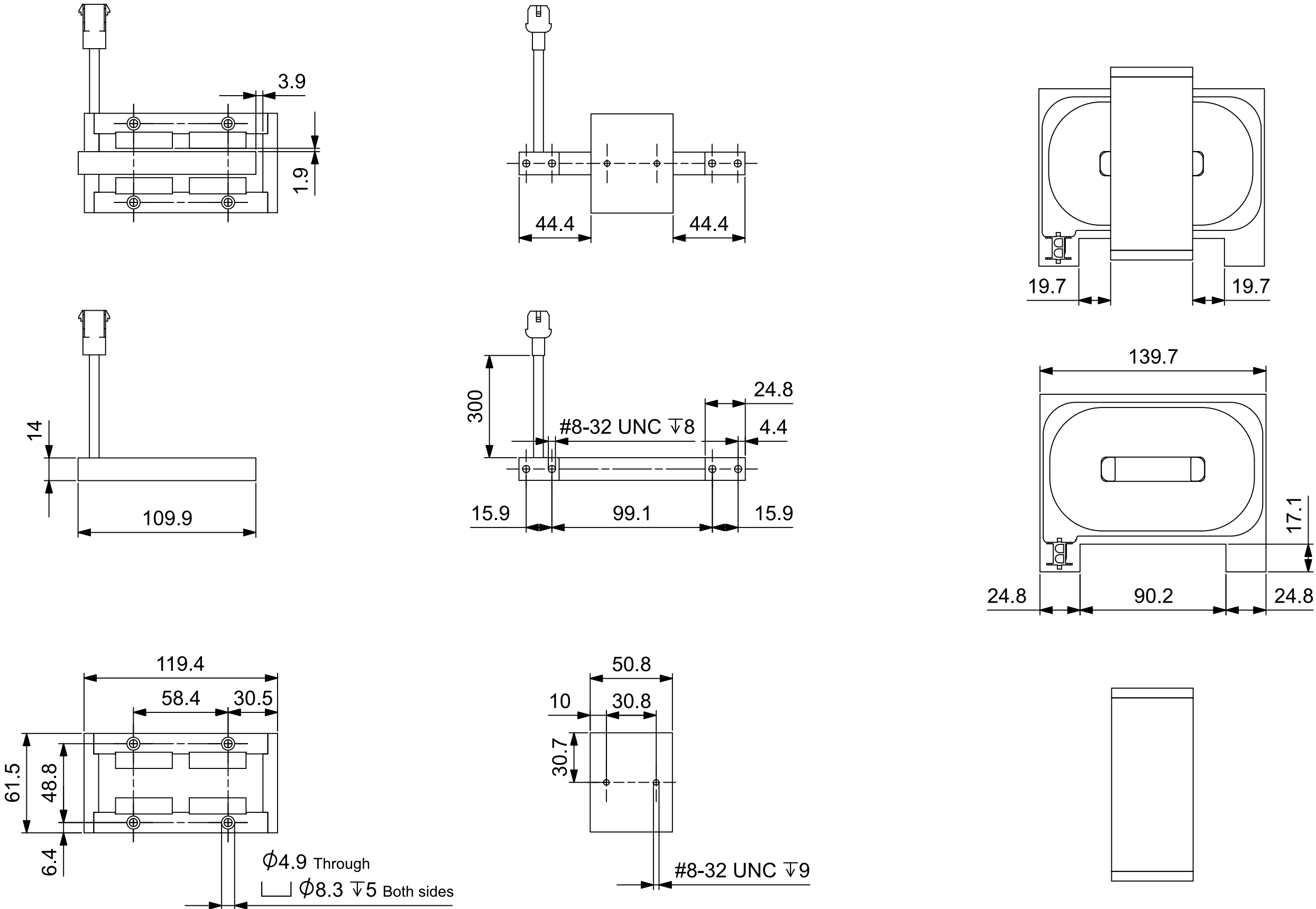

	Parameter	Symbol	Unit	S-05
Mass	Magnet yoke mass	M_{my}	kg	1.9
	Coil unit mass (incl. cable)	M_{cu}	kg	0.9
	Total mass (incl. cable)	M_{tot}	kg	2.8

IRIS-S-10 MECHANICAL SPECIFICATIONS

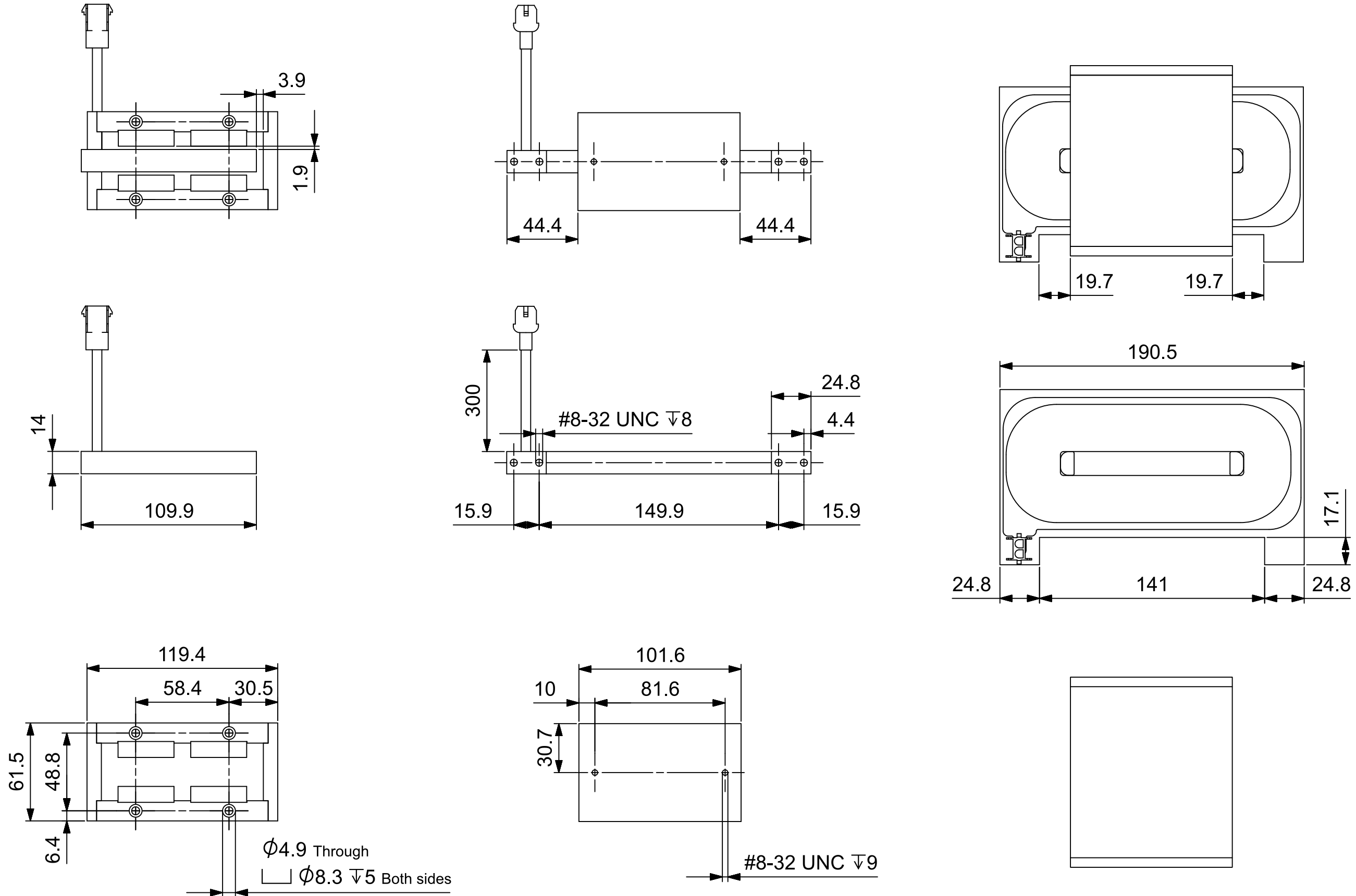

	Parameter	Symbol	Unit	S-10
Mass	Magnet yoke mass	M_{my}	kg	3.8
	Coil unit mass (incl. cable)	M_{cu}	kg	1.2
	Total mass (incl. cable)	M_{tot}	kg	5.0

IRIS-M-12 MECHANICAL SPECIFICATIONS

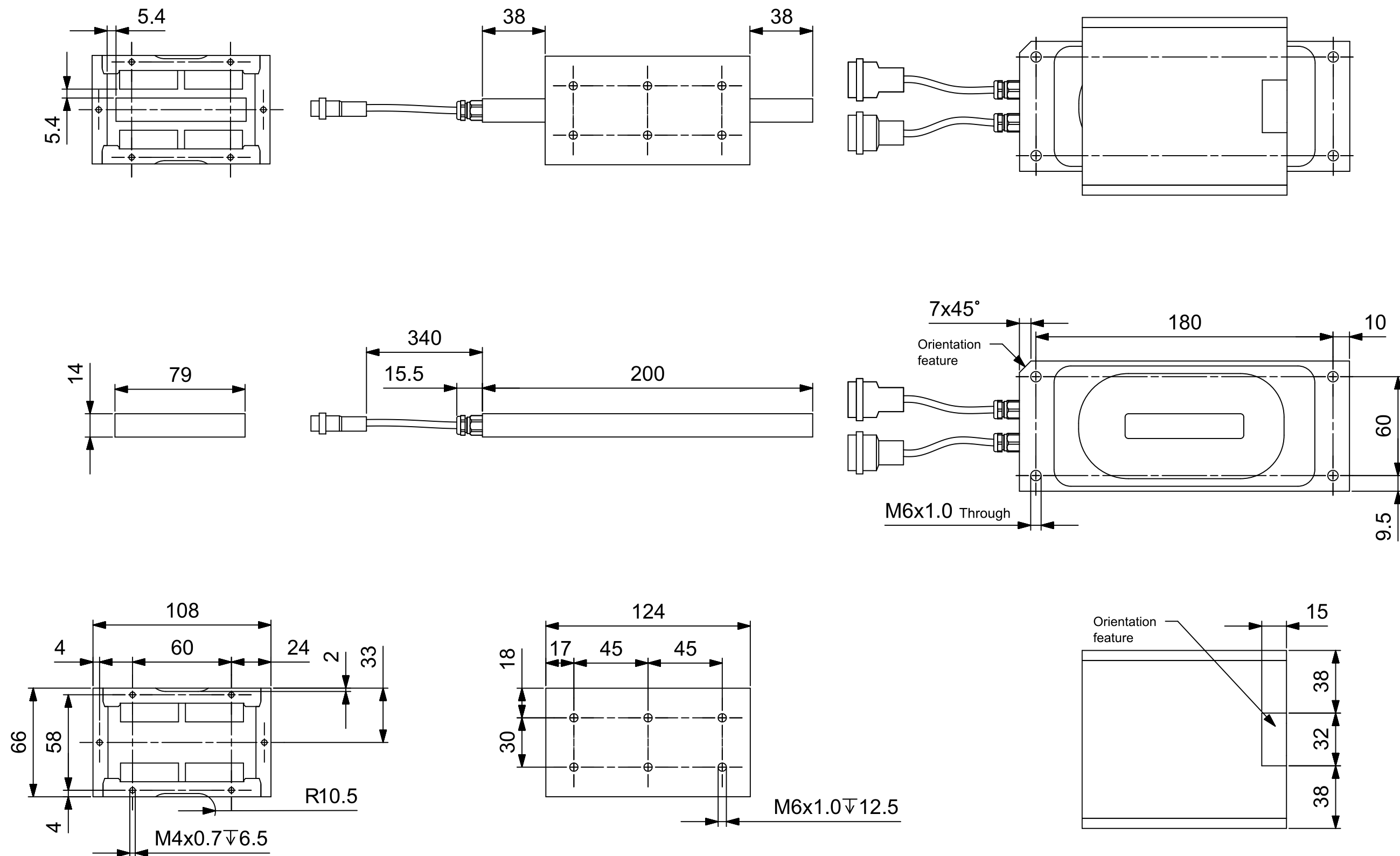

	Parameter	Symbol	Unit	M-12
Mass	Magnet yoke mass	M_{my}	kg	3.8
	Coil unit mass (incl. cable)	M_{cu}	kg	0.8
	Total mass (incl. cable)	M_{tot}	kg	4.6

IRIS-L-16 MECHANICAL SPECIFICATIONS

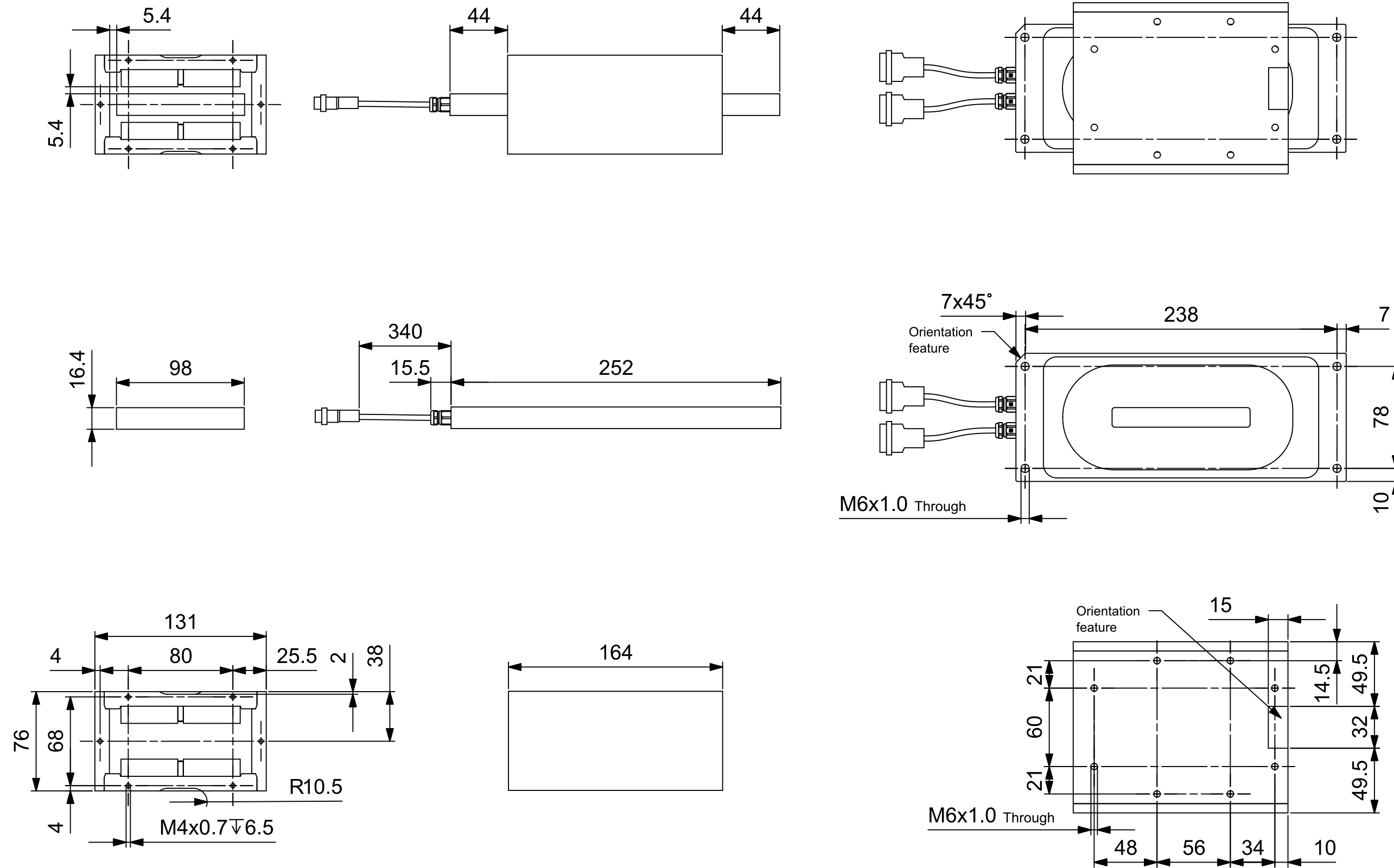

	Parameter	Symbol	Unit	L-16
Mass	Magnet yoke mass	M_{my}	kg	7.6
	Coil unit mass (incl. cable)	M_{cu}	kg	1.5
	Total mass (incl. cable)	M_{tot}	kg	9.1

DEFINITIONS

Parameter	Symbol / Equation	Unit	Remarks
Coil temperature	T_{coil}	°C	Average temperature over the complete coil volume
Interface temperature	T_{int}	°C	Average temperature over the complete interface surface
Convective surface temperature	T_{conv}	°C	Average temperature over the complete convective surface
Thermal resistance	$R_{th,i}$	K/W	From average coil temperature to average interface temperature
Thermal resistance	$R_{th,c}$	K/W	From average coil temperature to average convective surface temperature
Thermal time constant	τ_{th}	s	The time to reach 63.7% of the steady state temperature considering $T_{int} = 20^{\circ}\text{C}$

The actual continuous force is strongly dependent on the cooling conditions available in the application. Depending on the situation (vacuum environment, natural convection, forced convection or other), the thermal resistances of the coil unit ($R_{th,i}$ and $R_{th,c}$) should be combined with the thermal resistances of the cooling interfaces to determine the overall thermal resistance (R_{th}). This overall thermal resistance provides the maximum dissipated power and continuous force.

Please contact us for any support to calculate your specific application.

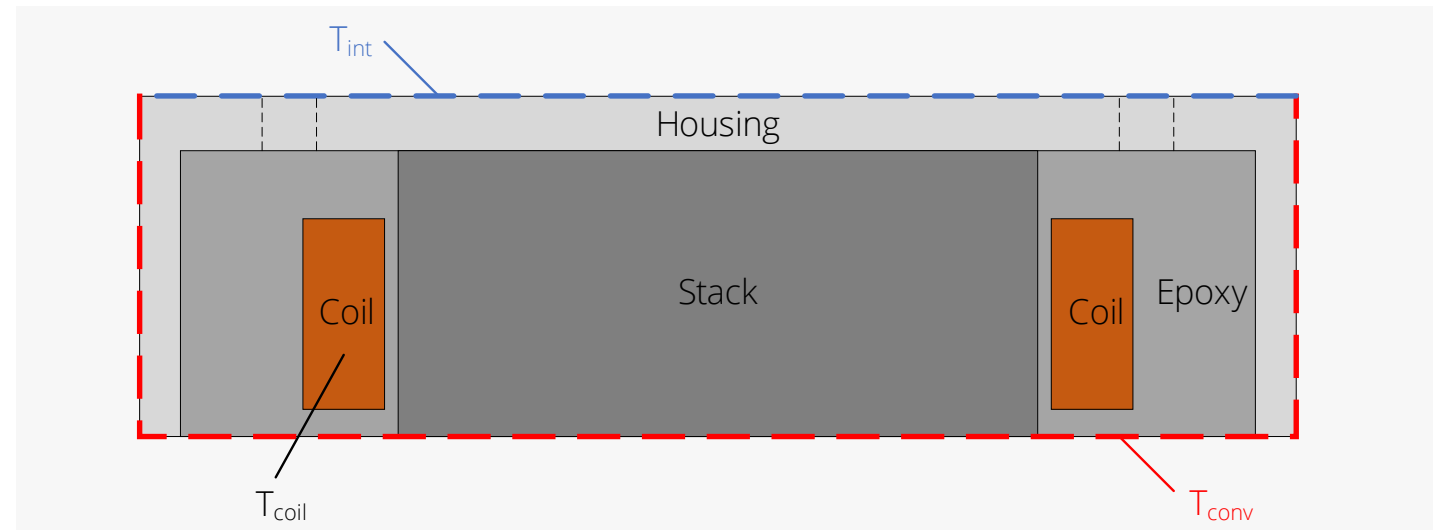

Chiron temperature definitions

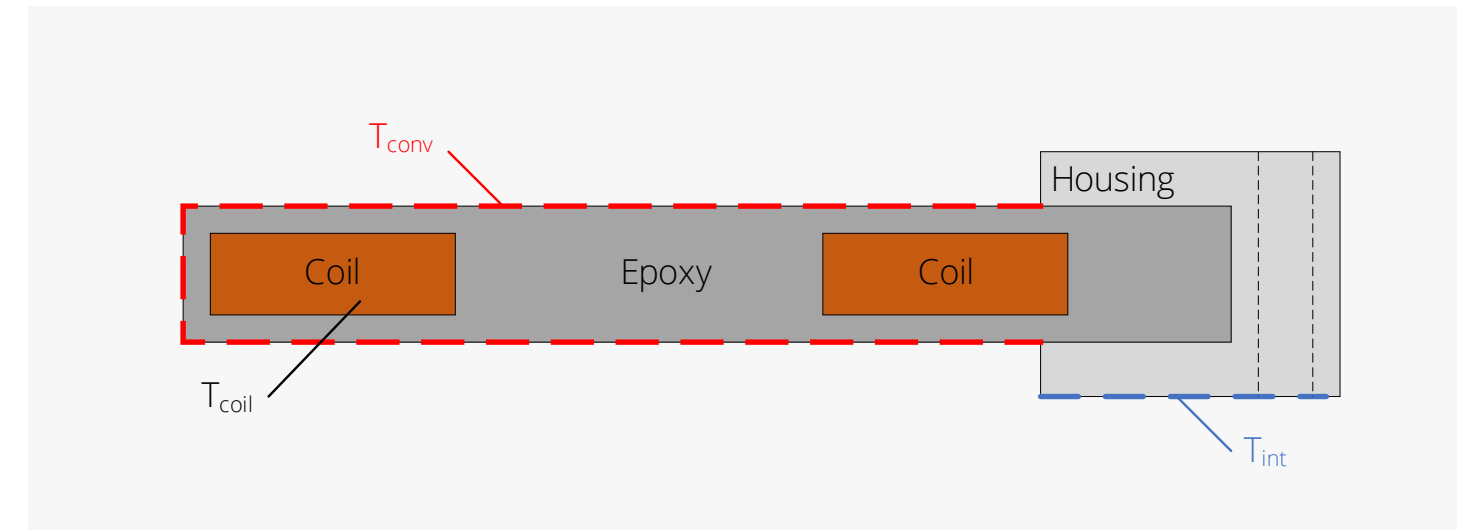

Phoenix / Gryphon temperature definitions

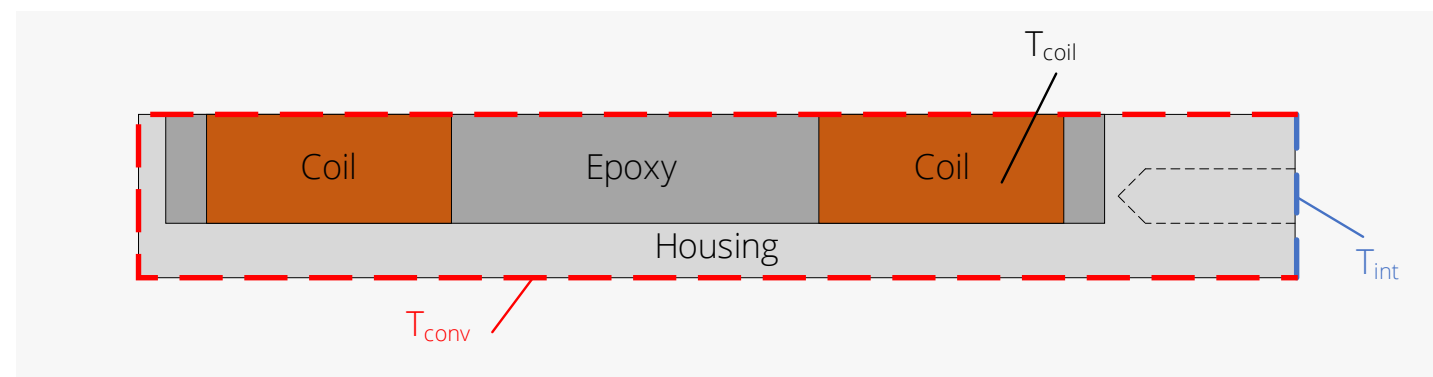

Iris-S temperature definitions

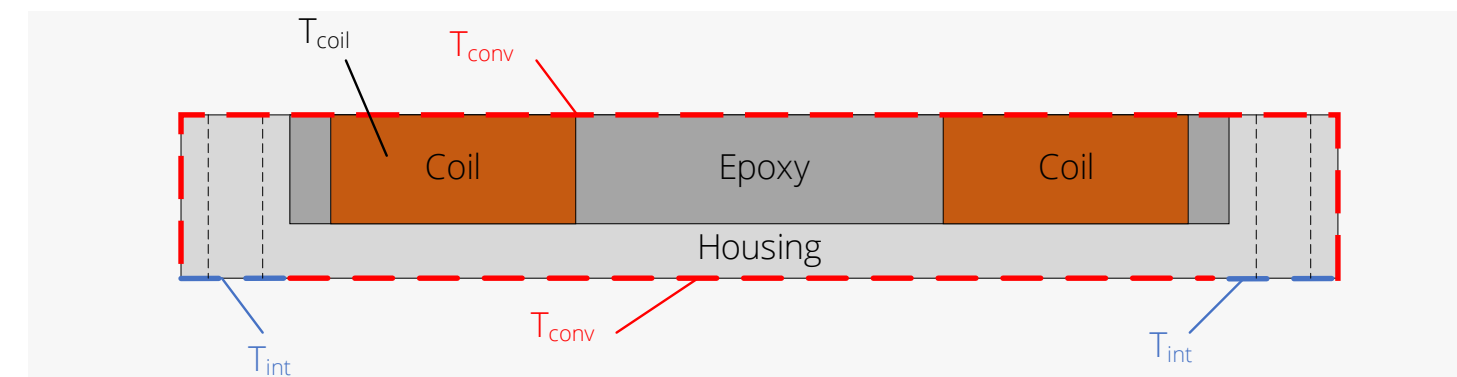

Iris-M/L temperature definitions

DEFINITIONS

Description	Equation	Unit	Remarks
Phase resistance at T_{coil}	$R_{ph} = R_{ph,20}(1+0.0039(T_{coil}-20))$	Ohm	
Force constant at no load	$K_f = K_e$	N/A	
Continuous dissipation	$P_{d,c} = (T_{coil} - T_{amb})/R_{th,i}$	W	Only copper losses are considered. This catalogue considers $T_{amb} = 20^\circ\text{C}$.
Peak dissipation	$P_{d,p} = C_{th} \alpha_T$	W	α_T is mentioned at the peak force specification.
Continuous rms current	$I_c = \min\left(\sqrt{\frac{P_{d,c}}{R_{ph}}}, \frac{V_{dc}}{R_{ph}}\right)$	A	Limited either by continuous dissipation or dc voltage and resistance or cable/connector ratings (if applicable).
Peak rms current	$I_p = \min\left(\sqrt{\frac{P_{d,p}}{R_{ph,20}}}, \frac{V_{dc}}{R_{ph,20}}\right)$	A	Limited either by peak dissipation or dc voltage and resistance or cable/connector ratings (if applicable).
Continuous force	$F_c = K_f I_c$	N	
Peak force	$F_p = K_f I_p$	N	
Motor constant	$S = \frac{K_f^2}{R_{ph,20}}$	N ² /W	

CONTACT

Phone: +31 (0)40 2676200

E-mail: sales@prodrive-technologies.com

Web: www.prodrive-technologies.com

February 2023

The content of this catalog is subject to change without prior notice