

LINEAR MOTOR CATALOG

PHOENIX

Ironless Motors

TABLE OF CONTENTS

A Passion for Technology	3
Overview	4
Winding Configurations	6
Phoenix Line	7
T Features	8
T Performance Specifications	9
T Mechanical Specifications Without CS	10
T Mechanical Specifications With CS	11
S/M/L/X/U Features	12
S Performance Specifications	13
S Mechanical Specifications	14
M Performance Specifications	15
M Mechanical Specifications	16
L Performance Specifications	17
L Mechanical Specifications	18
X Performance Specifications	19
X Mechanical Specifications	20
U Performance Specifications	21
U Mechanical Specifications	22
T/S Force-Velocity Diagrams	23
M/L Force-Velocity Diagrams	24
X/U Force-Velocity Diagrams	25
Phoenix Commutation Sensors	26
Definitions	27
Contact	29

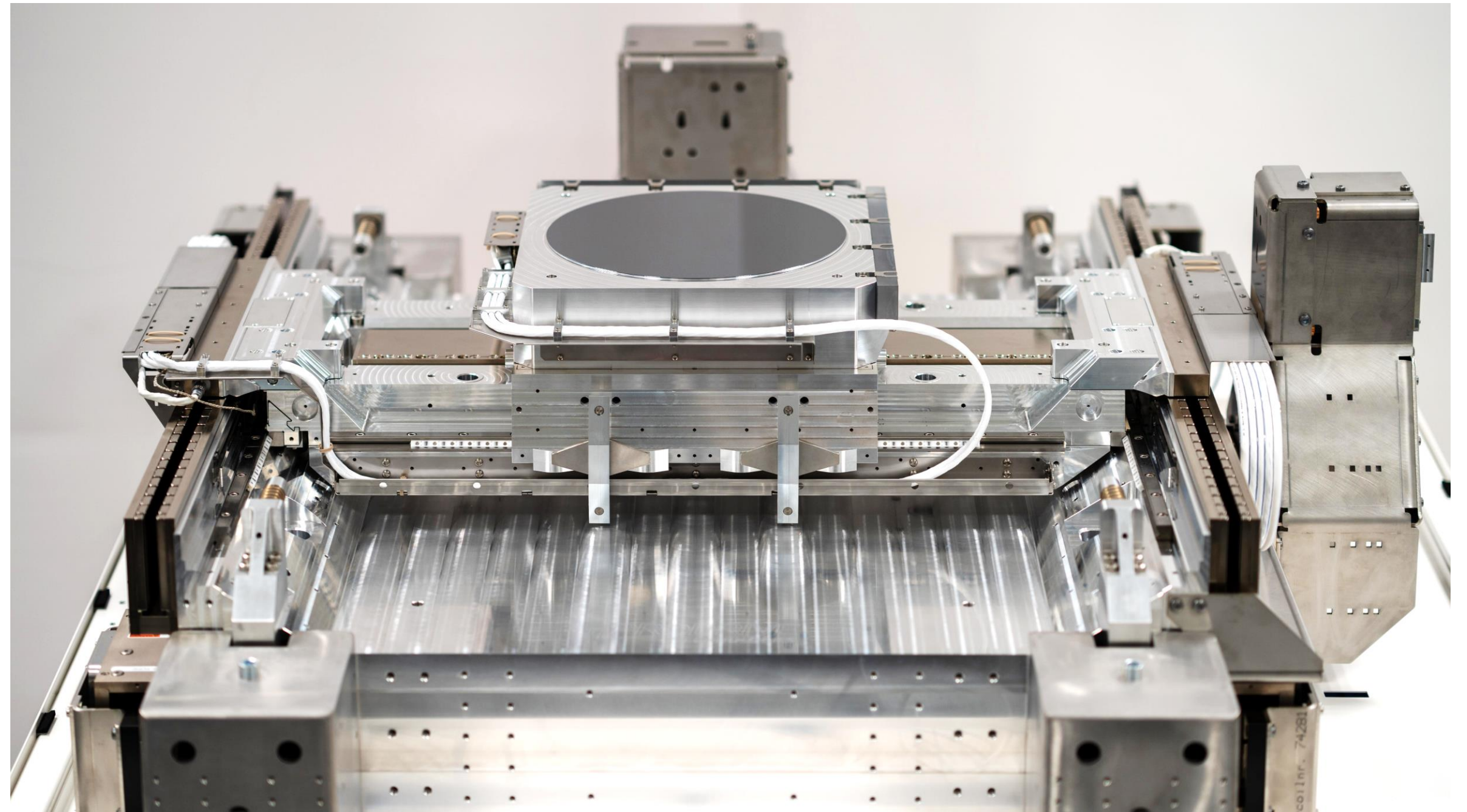

Linear motors integrated in a motion stage

Knowledge

Engineering excellence is the driving force behind linear motor innovation in both design and manufacturing. Prodrive has a highly skilled group of (electro-)mechanical engineers capable of customizing linear motor technology towards your needs.

Quality

Quality is in the DNA of Prodrive Technologies. With a long history in electronics manufacturing, Prodrive continues in the area of linear motor manufacturing with the same philosophy and processes, setting a new standard within the linear motor market.

Automation

Design for manufacturing is key to reduce cost and guarantee quality. Winding, assembly, vacuum potting and magnet gluing are highly automated processes which guarantees a constant quality at minimum cost.

Time to market

Due to the agility of Prodrive Technologies' large development department, customization can be performed in a very short time, providing a short time to market for challenging mechatronic applications.



Prodrive Technologies HQ Campus, The Netherlands

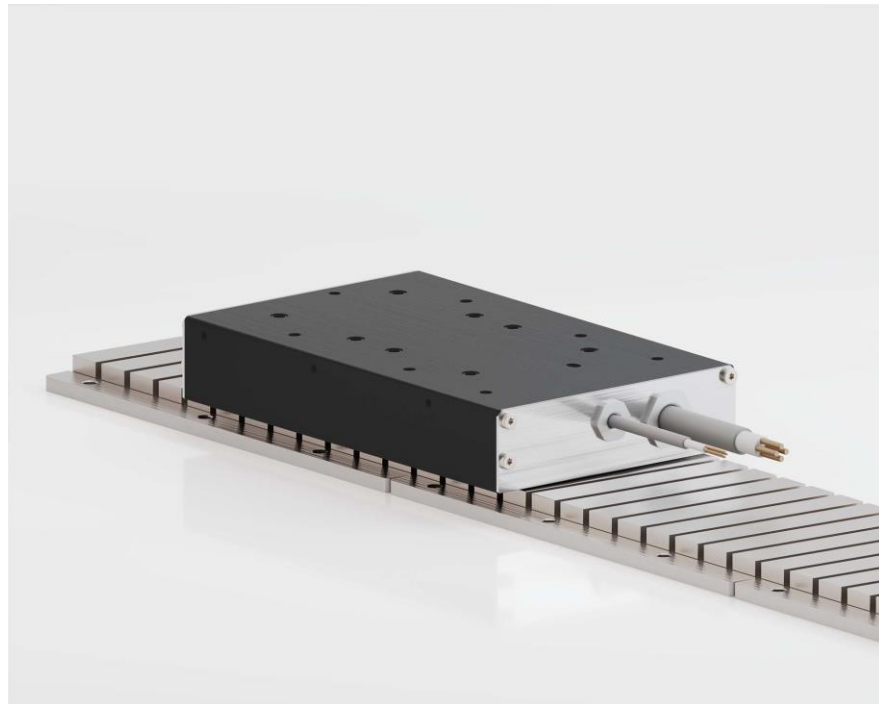

Chiron

The Chiron line offers iron core linear motors which are optimized for high force and high efficiency. Find the optimal fit for your application due to the many different available form factors.



Phoenix

The Phoenix line offers ironless linear motors, for applications requiring an extremely low force ripple for excellent servo performance without attraction forces. Available in a large range of sizes.



Gryphon

The Gryphon line offers a cost-effective solution for vacuum-compatible ironless linear motors. These motors also contain features providing magnetic shielding.

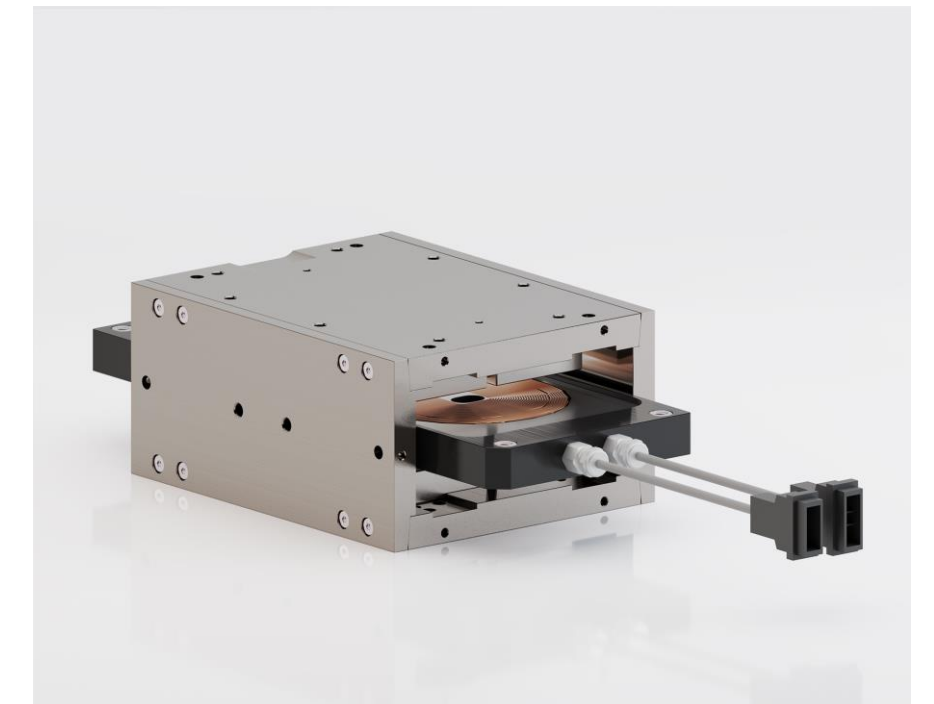

Iris

For short stroke applications requiring a relatively large displacement in three directions, the Iris line provides a high force density with zero attraction forces in a rectangular form factor.

OVERVIEW

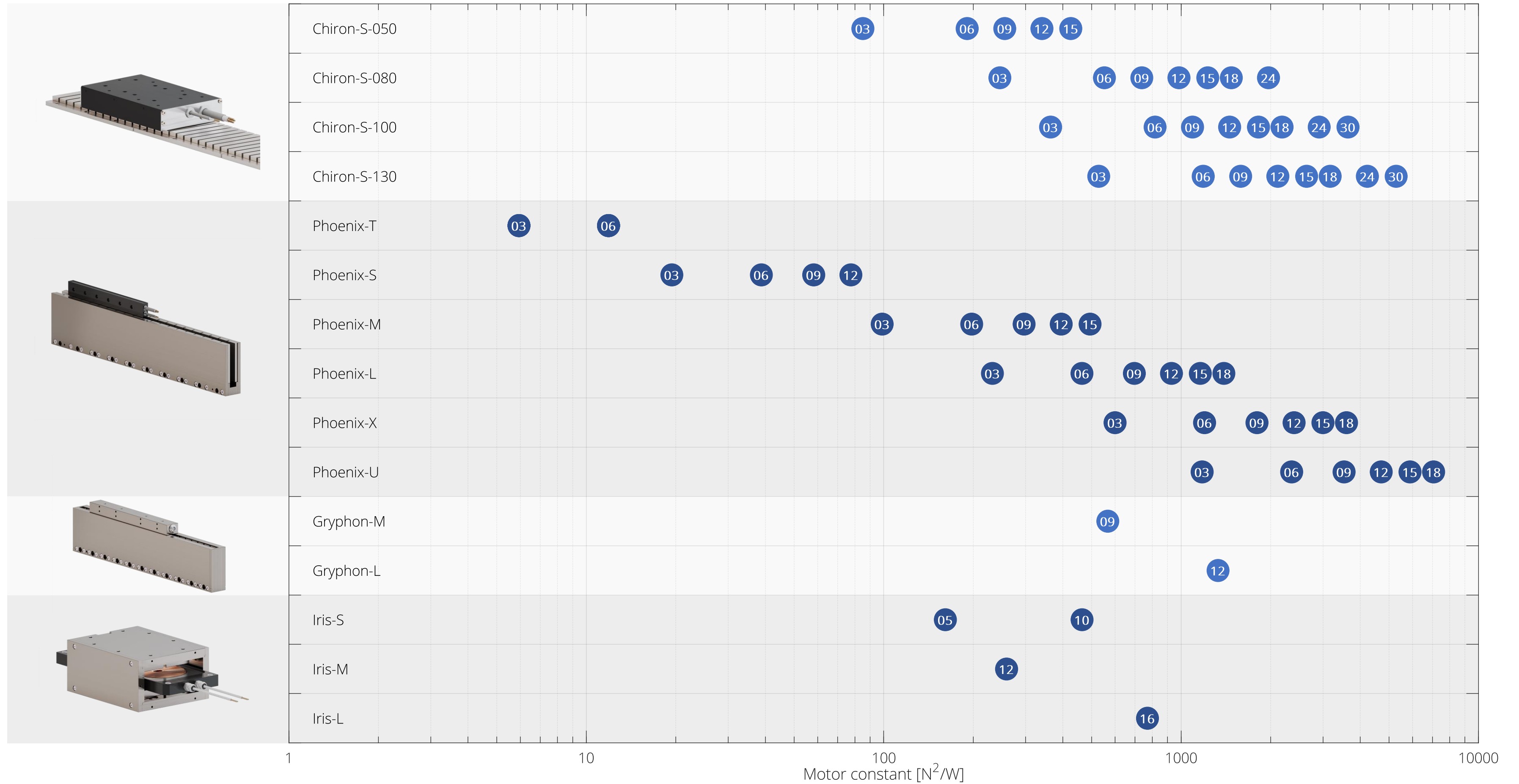

WINDING CONFIGURATIONS

The phases of all three-phase linear motors are star-connected.

The Chiron, Phoenix and Gryphon line can be selected with different winding configurations to create an optimal fit for your application.

Winding configuration A

The windings are configured such that independent of the number of coils, the force constant remains equal, and the maximum velocity remains unchanged. The maximum current increases with the number of coils.

Winding configuration B

The windings are configured like winding configuration A, but this winding configuration can reach higher velocities at the expense of a lower force constant.

Winding configuration C

The windings are configured such that the current remains constant with increasing number of coils at the expense of reducing the maximum velocity. For the Chiron, Phoenix and Gryphon line, this configuration allows moving magnet applications with partial coil unit overlap.

Winding configuration D

The windings are configured such that the current remains constant with increasing number of coils at the expense of reducing the maximum velocity. This configuration has a higher maximum velocity compared to winding configuration C. For the Phoenix line, this configuration allows moving magnet applications with partial coil unit overlap.

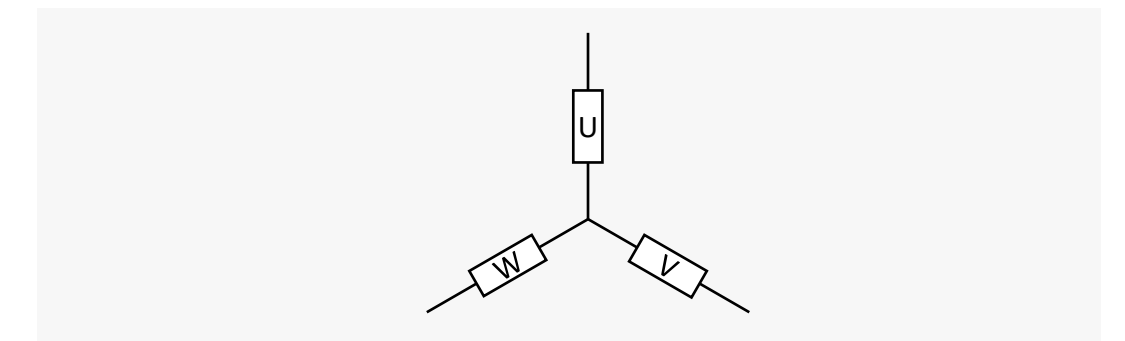

Phase connection chart

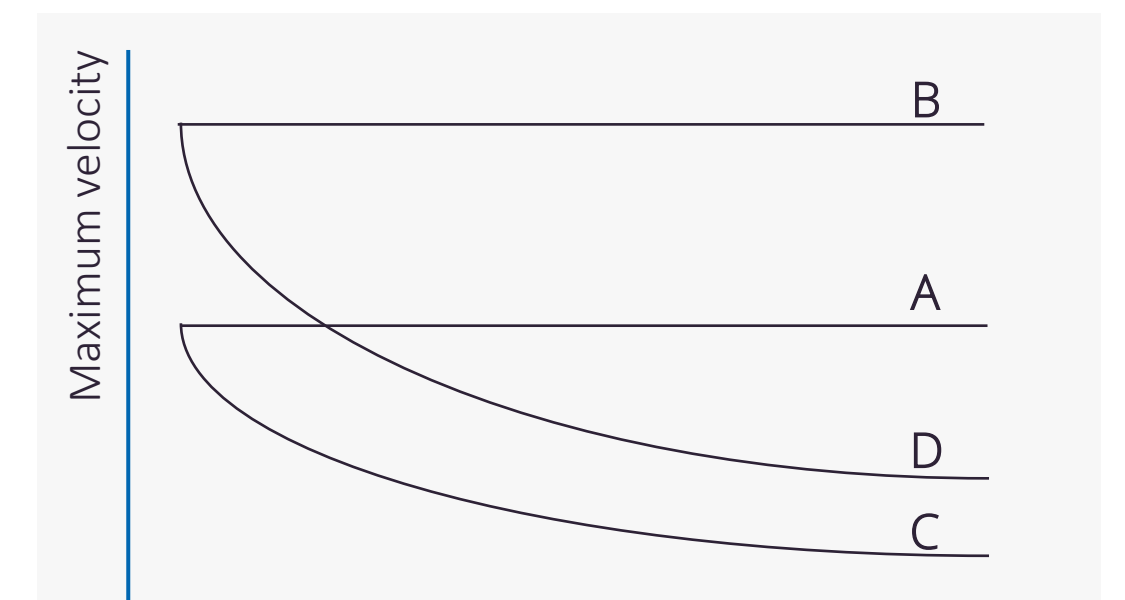

Number of coils

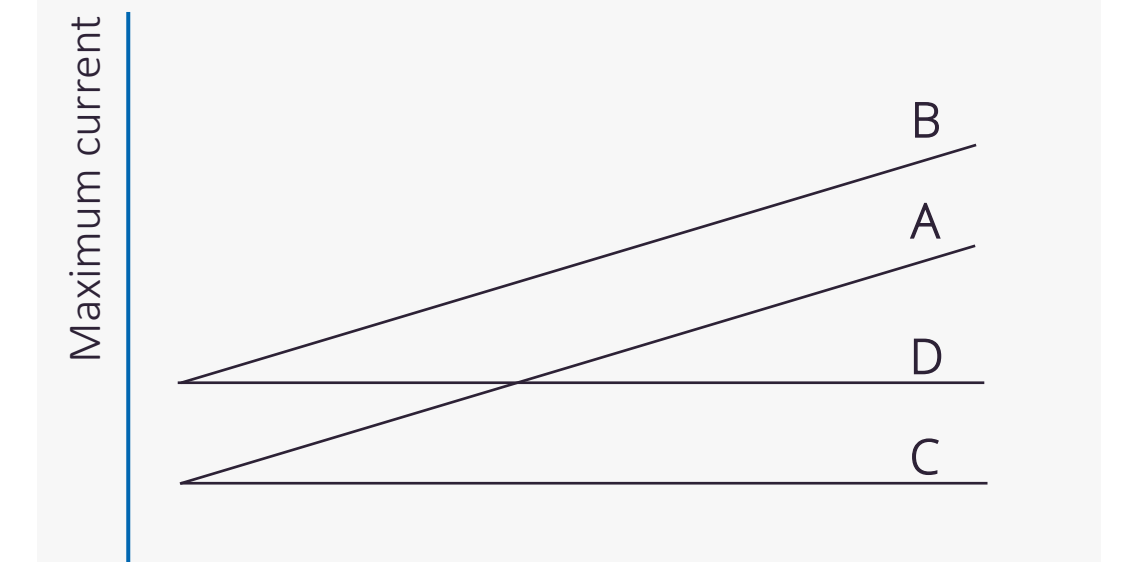

Number of coils

Winding configurations chart

PHOENIX LINE

The Phoenix line offers ironless linear motors, for applications requiring an extremely low force ripple for excellent servo performance without attraction forces. Available in a large range of sizes.

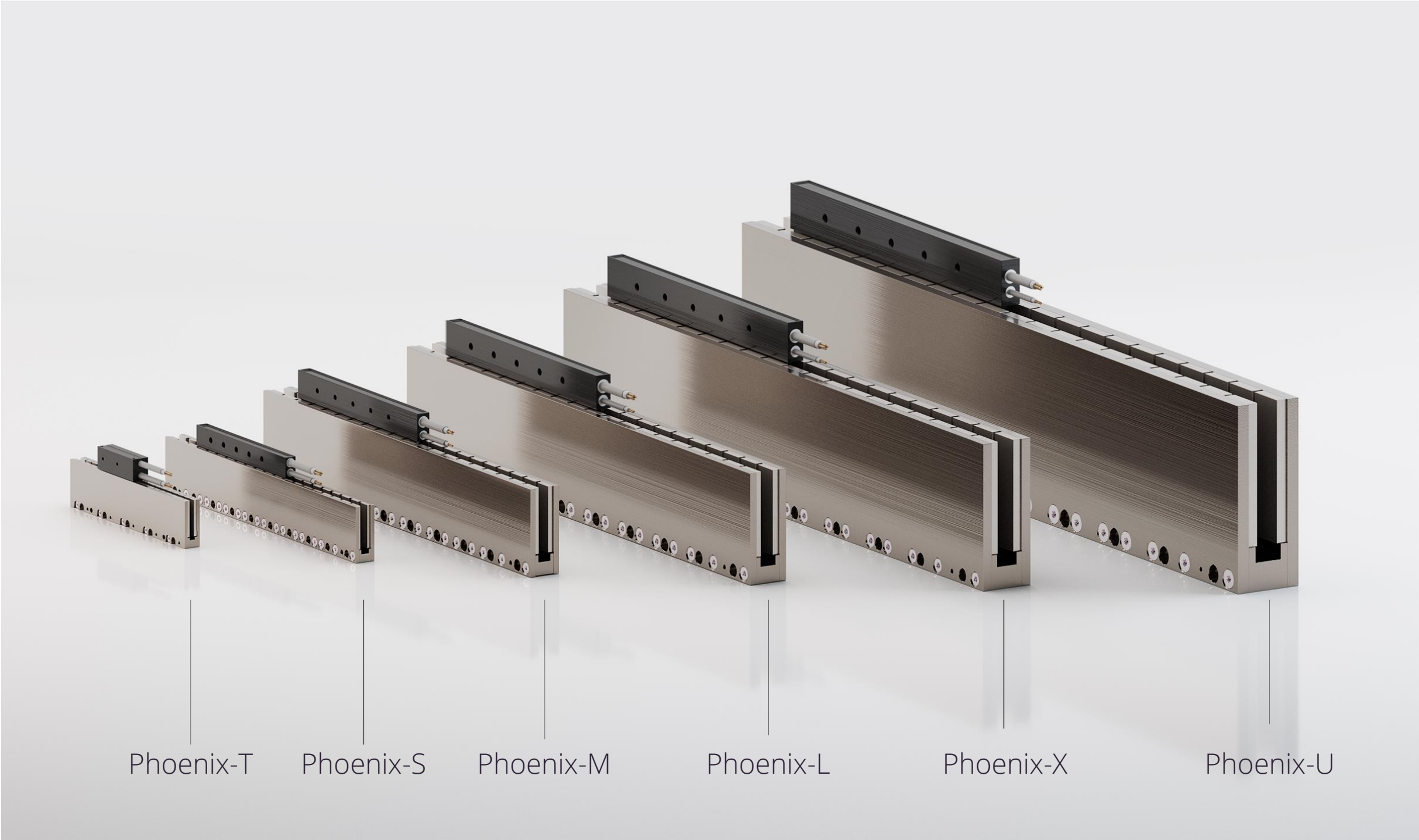

Phoenix line linear motors in different sizes

PHOENIX-T FEATURES

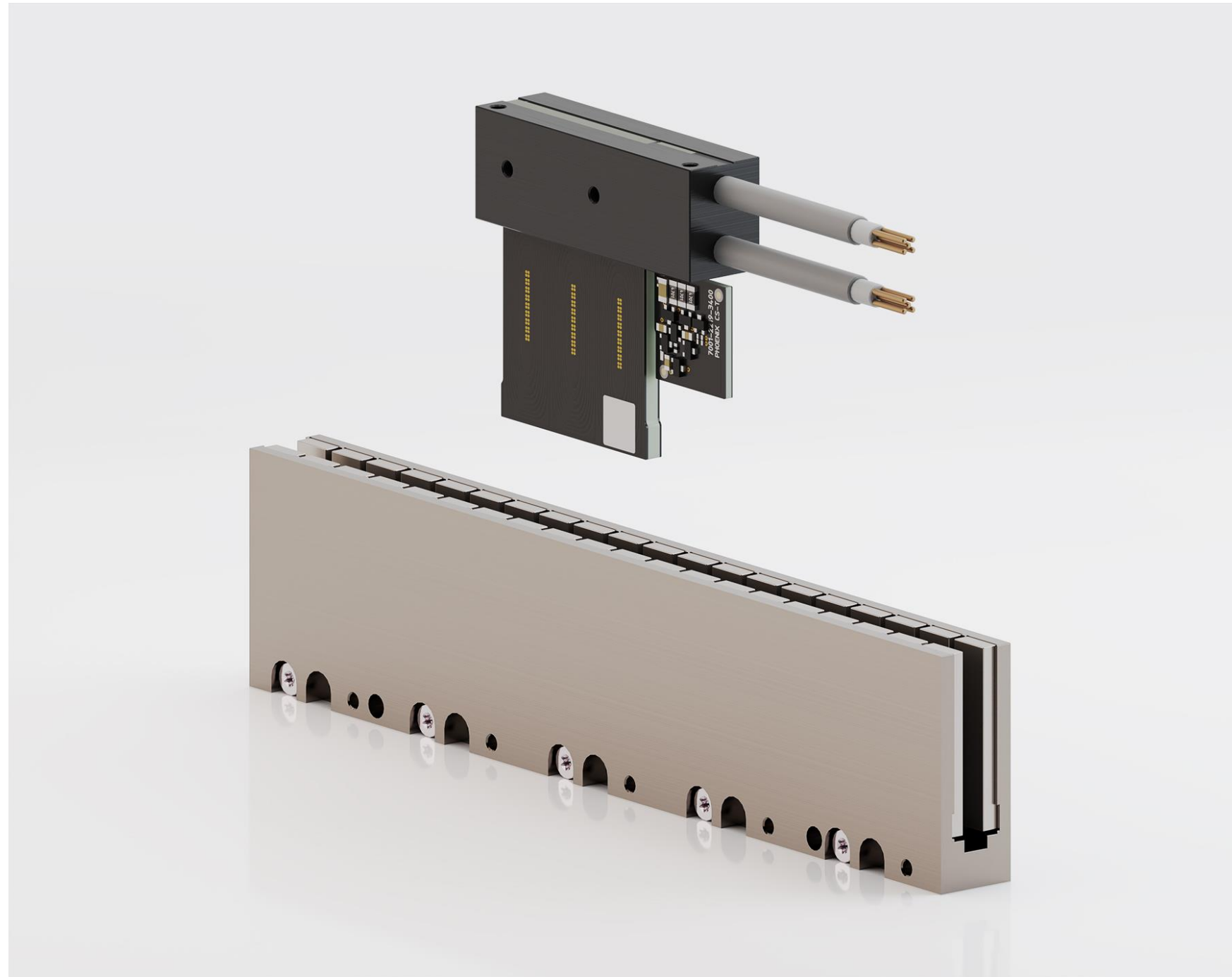

Phoenix-T magnet yoke (Phoenix-MY-T-20-G00) and coil unit (Phoenix-CU-T-03-C-S-P-CS)

Phoenix-CU-T-06-A-S-P-CS

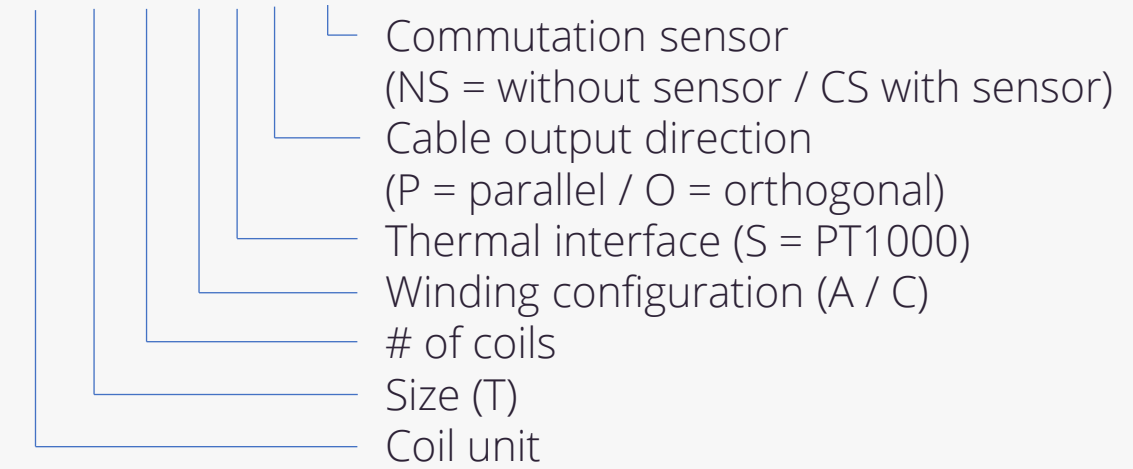

Phoenix-MY-T-20-G00

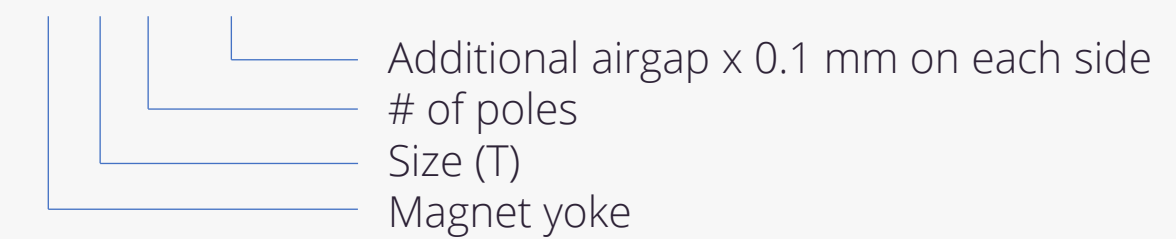

- Different cable output directions for optimal mechanical integration
- Coil units have a temperature sensor (PT1000)
- Motor phases and temperature sensor are integrated in a single cable
- Motor coils are made with PCB technology to improve quality and minimize cost
- Optional commutation sensor (CS), digital Hall, integrated in the coil unit
- Magnet yokes can be butted together
- Magnet yokes can be selected with larger airgaps to allow higher installation tolerances
- Extremely low force ripple due to ironless coil unit
- No attraction force
- Coil units are equipped with flex cables

PHOENIX-T PERFORMANCE SPECIFICATIONS

	Parameter	Symbol	Unit	T _{coil} (°C)	CU-T-03	CU-T-06
	Winding configuration	-	-	-	C	A
Electromechanical	Peak force (α _T = 20°C/s increase)	F _p	N	20	26	52
	Continuous force, interface at 20°C	F _c	N	100	9	17
	Attraction force (I = 0)	F _{att}	N	-	0	0
	Motor constant	S	N ² /W	20	6	12
	Force constant	K _f	N/A _{rms}	-	10.2	10.2
	Maximum velocity (F = 0)	v _m	m/s	-	7.2	7.2
	Maximum velocity (F = F _p)	v _i	m/s	20	2.8	2.8
Electrical	Maximum dc bus voltage	V _{dc}	V	-	60	60
	Phase resistance	R _{ph,20}	Ohm	20	5.8	2.9
	Phase inductance	L _{ph}	mH	20	0.50	0.25
	Peak line emf constant	K _{e,ll,p}	Vs/m	-	8	8
	Maximum rms current	I _p	A _{rms}	20	2.5	5.1
	Continuous rms current, interface at 20°C	I _c	A _{rms}	100	0.8	1.7
Thermal	Continuous dissipation, interface at 20°C	P _{d,c}	W	100	16	33
	Thermal resistance, coils to interface	R _{th,i}	K/W	-	4.9	2.5
	Thermal resistance, coils to conv. surface	R _{th,c}	K/W	-	0.58	0.29
	Thermal time constant, interface at 20°C	τ _{th}	s	-	45	45

Notes

- Specifications are based upon a magnet temperature of 20°C
- Specifications consider complete overlap of coil unit/magnet yoke
- Specifications consider sinusoidal q-axis commutation
- Velocity specifications are based on the maximum bus voltage
- Specifications consider a magnet yoke with nominal airgap (G00)
- See 'definitions' section at the end of the catalog for more details

Power/PT1000 Interface:

- Phase U (White)
- Phase V (Brown)
- Phase W (Green)
- PT1000 (Yellow)
- PT1000 (Grey)

Comm. Sensor Interface:

- GND (White)
- VCC (Brown)
- Hall A (Green)
- Hall B (Yellow)
- Hall C (Grey)

Electrical interfaces

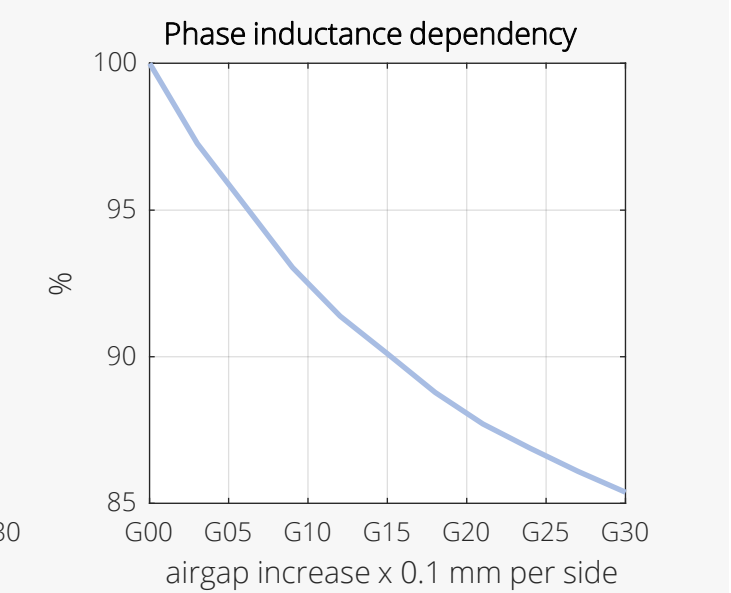
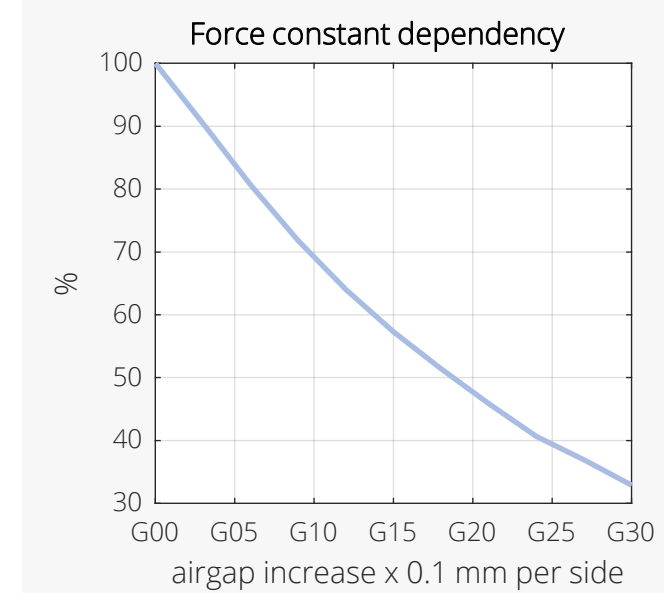

Airgap dependency

PHOENIX-T MECHANICAL SPECIFICATIONS WITHOUT CS

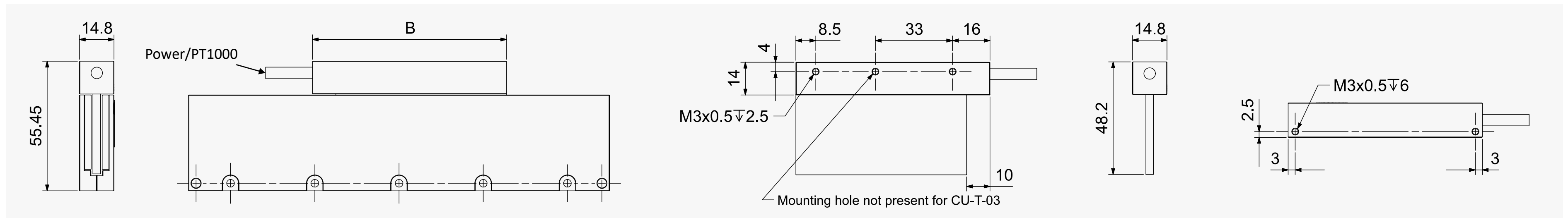

Parallel cable output

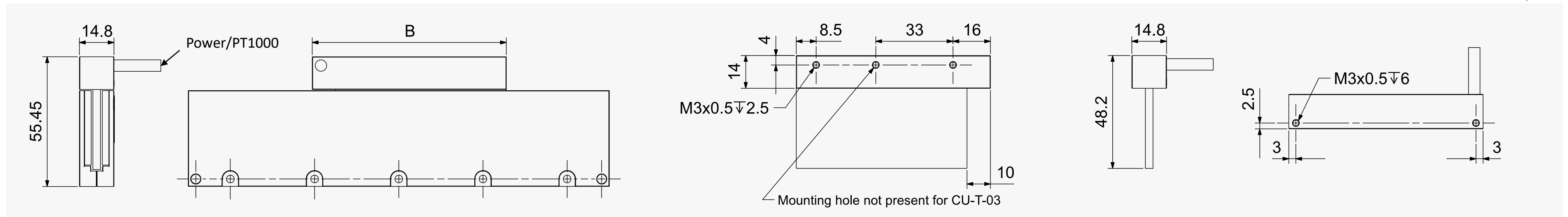

Orthogonal cable output

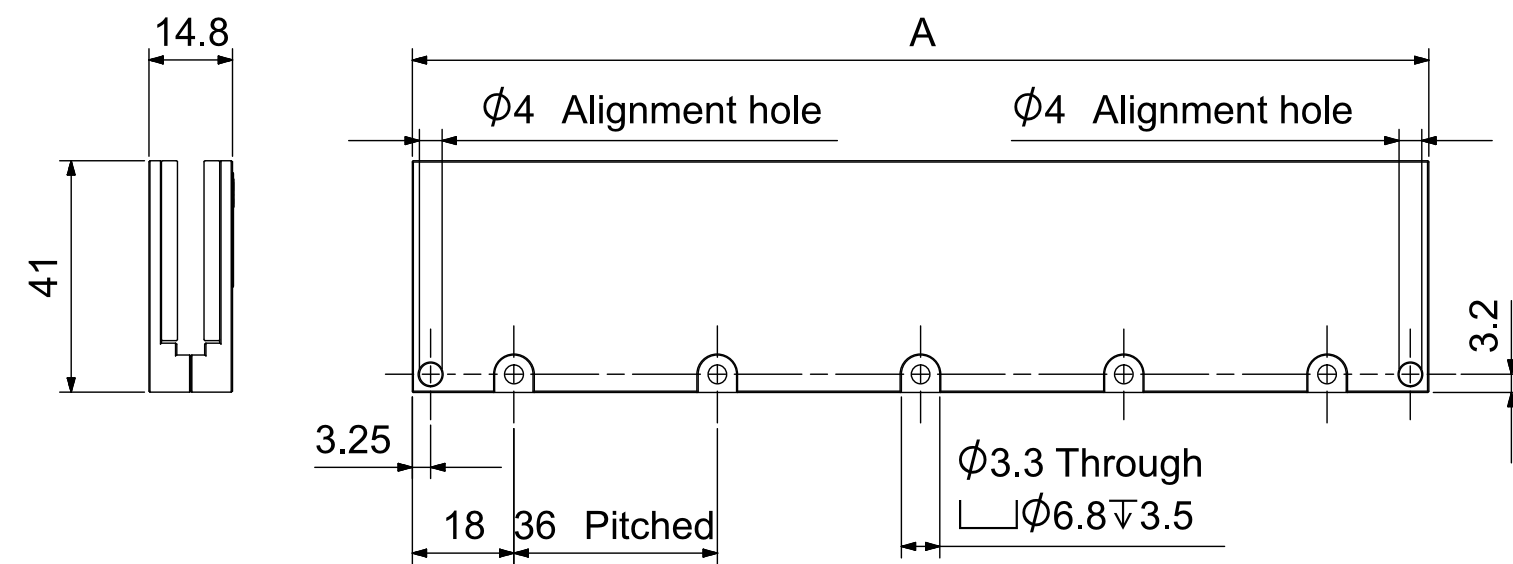

Magnet Yokes	Parameter	Symbol	Unit	MY-T-08	MY-T-12	MY-T-16	MY-T-20
	Number of poles	N_p	-	8	12	16	20
	Pole pitch (N-N)	$2\tau_p$	mm	18	18	18	18
	Width	A	mm	72	108	144	180
Mass	M_{my}	kg	0.21	0.32	0.43	0.53	

Coil Units	Parameter	Symbol	Unit	CU-T-03	CU-T-06
	Number of coils	N_{coil}	-	3	6
	Coil pitch	τ_{coil}	mm	12	12
	Width	B	mm	47	83
	Mass (ex. cable)	M_{cu}	kg	0.038	0.071
Standard cable length	L_{cable}	m	1	1	

PHOENIX-T MECHANICAL SPECIFICATIONS WITH CS

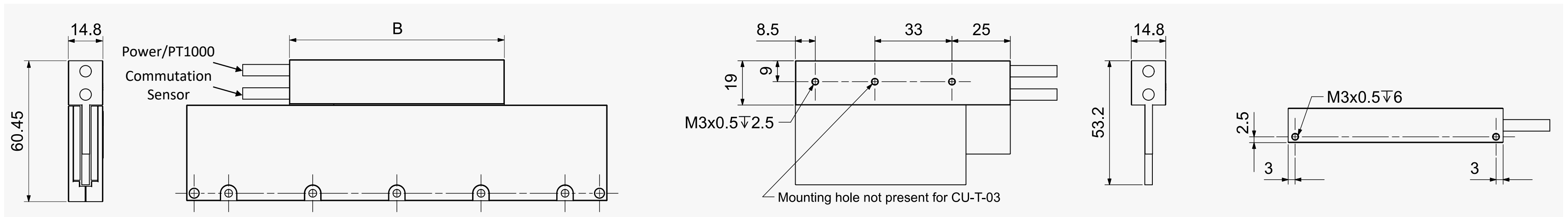

Parallel cable output

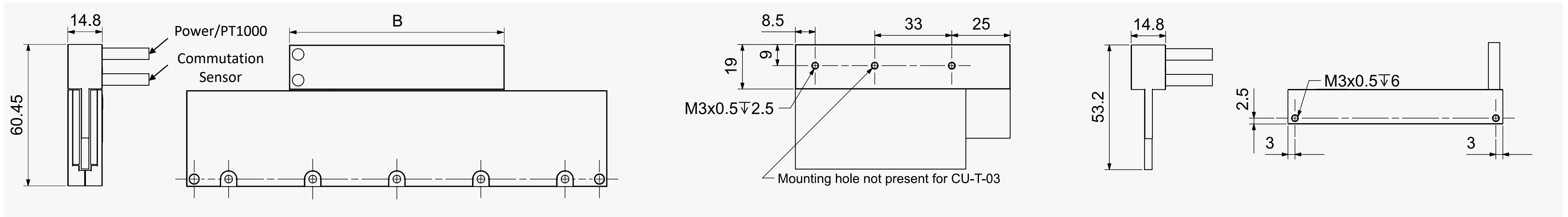

Orthogonal cable output

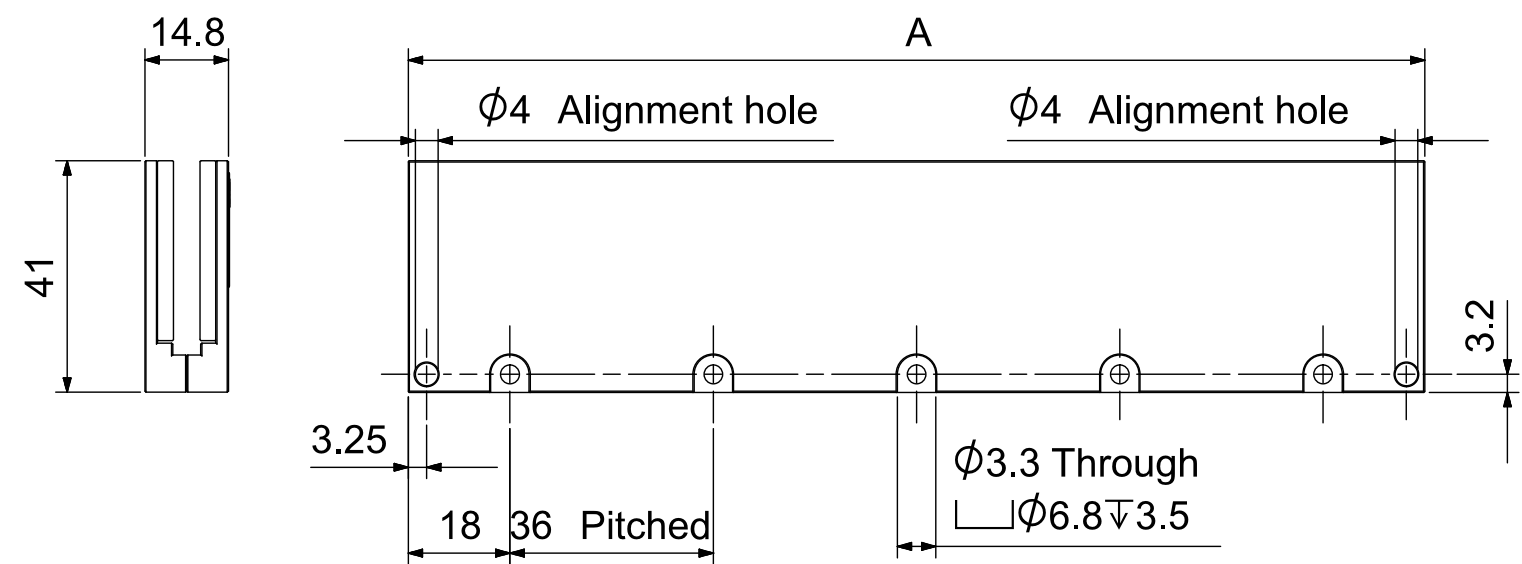

Magnet Yokes	Parameter	Symbol	Unit	MY-T-08	MY-T-12	MY-T-16	MY-T-20
	Number of poles	N_p	-	8	12	16	20
	Pole pitch (N-N)	$2\tau_p$	mm	18	18	18	18
	Width	A	mm	72	108	144	180
	Mass	M_{my}	kg	0.21	0.32	0.43	0.53

Coil Units	Parameter	Symbol	Unit	CU-T-03	CU-T-06
	Number of coils	N_{coil}	-	3	6
	Coil pitch	τ_{coil}	mm	12	12
	Width	B	mm	56	92
	Mass (ex. cable)	M_{cu}	kg	0.051	0.089
Standard cable length	L_{cable}	m	1	1	

PHOENIX-S/M/L/X/U FEATURES



Phoenix-S magnet yoke (Phoenix-MY-S-20-G00), coil unit (Phoenix-CU-S-06-A-B) and commutation sensor (Phoenix-CS-S)

Phoenix-CU-M-12-A-N

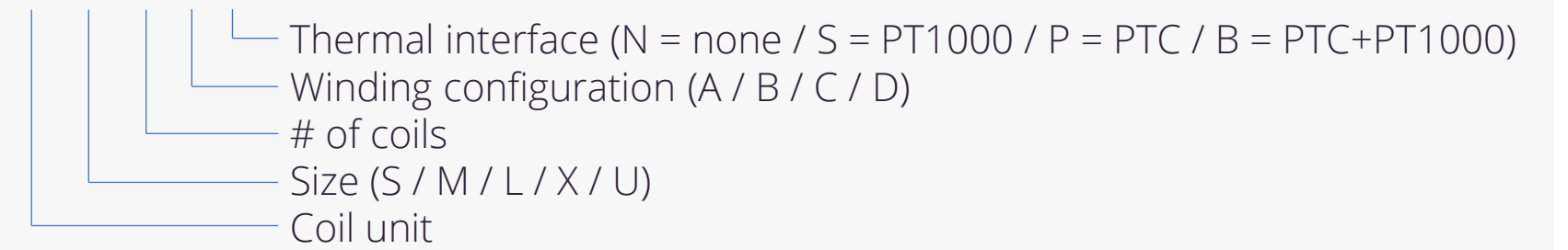

Phoenix-MY-M-20-G00

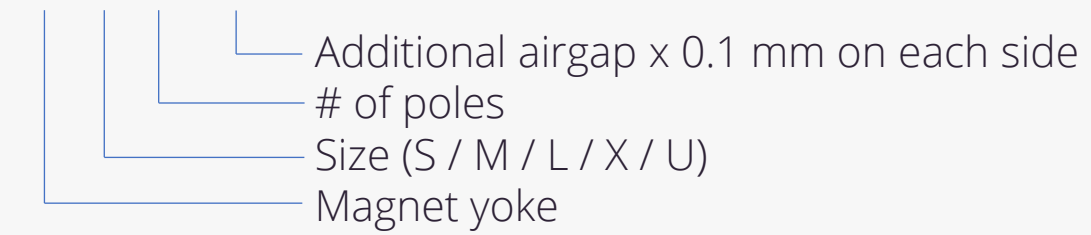

Phoenix-CS-M



- Multiple sizes for optimal mechanical integration
- Multiple winding configurations for optimal current/velocity matching
- Coil units have an optional temperature protection (PTC) and/or sensor (PT1000)
- Magnet yokes can be butted together
- Magnet yokes can be selected with larger airgaps to accommodate larger tolerances
- Extremely low force ripple due to ironless coil unit
- No attraction force
- IP rating of coil units is IP69K
- Optional commutation sensor (digital Hall A/B/C) can be connected to the coil unit

PHOENIX-S PERFORMANCE SPECIFICATIONS

Parameter		Symbol	Unit	T _{coil} (°C)	CU-S-03		CU-S-06			CU-S-09			CU-S-12	
Winding configuration		-	-	-	C	D	A	B	C	A	C	D	C	D
Electromechanical	Peak force ($\alpha_T = 20^\circ\text{C/s}$ increase)	F_p	N	20	80		160			230			310	
	Continuous force, interface at 20°C	F_c	N	100	25		50			75			95	
	Attraction force ($I = 0$)	F_{att}	N	-	0		0			0			0	
	Motor constant	S	N^2/W	20	20		40			60			80	
	Force constant	K_f	$\text{N}/\text{A}_{\text{rms}}$	-	17	8.6	17	8.6	34	17	51	26	68	34
	Maximum velocity ($F = 0$)	v_m	m/s	-	29	57	29	57	14	29	9.5	19	7.2	14
	Maximum velocity ($F = F_p$)	v_i	m/s	20	24	52	24	52	10	24	5.4	15	3.1	10
Electrical	Maximum dc bus voltage	V_{dc}	V	-	400		400			400			400	
	Phase resistance	$R_{ph,20}$	Ohm	20	5.0	1.3	2.5	0.6	10	1.7	15	3.8	20	5.0
	Phase inductance	L_{ph}	mH	20	1.5	0.4	0.7	0.2	3.0	0.5	4.4	1.1	5.9	1.5
	Peak line emf constant	$K_{e,ll,p}$	Vs/m	-	14	7.0	14	7.0	28	14	42	21	56	28
	Maximum rms current	I_p	A_{rms}	20	4.5	9.1	9.1	18.2	4.5	13.6	4.5	9.1	4.5	9.1
	Continuous rms current, interface at 20°C	I_c	A_{rms}	100	1.4	2.8	2.8	5.7	1.4	4.2	1.4	2.8	1.4	2.8
Thermal	Continuous dissipation, interface at 20°C	$P_{d,c}$	W	100	40		79			119			159	
	Thermal resistance, coils to interface	$R_{th,i}$	K/W	-	2.0		1.0			0.67			0.5	
	Thermal resistance, coils to conv. surface	$R_{th,c}$	K/W	-	0.19		0.093			0.062			0.047	
	Thermal time constant, interface at 20°C	τ_{th}	s	-	65		65			65			65	

Notes

- Specifications are based upon a magnet temperature of 20°C
- Specifications consider complete overlap of coil unit/magnet yoke
- Specifications consider sinusoidal q-axis commutation
- Velocity specifications are based on the maximum bus voltage
- Specifications consider a magnet yoke with nominal airgap (G00)
- See 'definitions' section at the end of the catalog for more details

Product marking / approvals



Power Interface:

- Phase U (L1)
- Phase V (L2)
- Phase W (L3)
- PE (Green/Yellow)

Thermal Interface (only N/S/P):

- PT1000 (White)
- PT1000 (Brown)
- or
- PTC (Green)
- PTC (Yellow)

Electrical interfaces

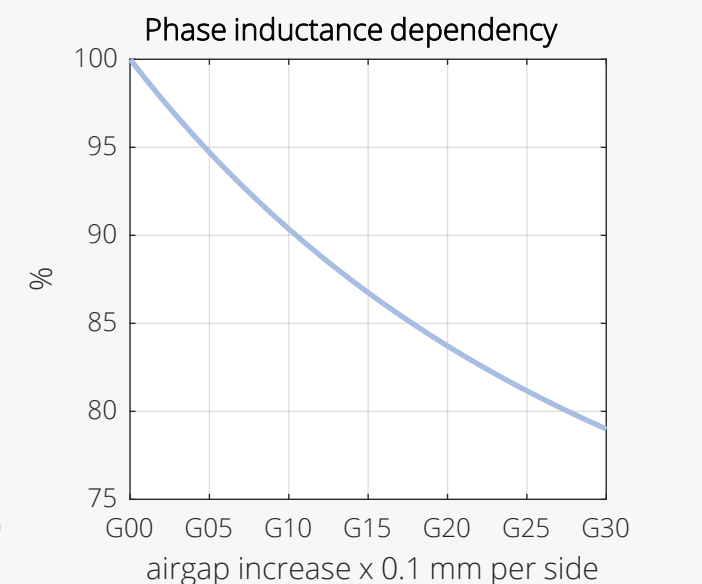
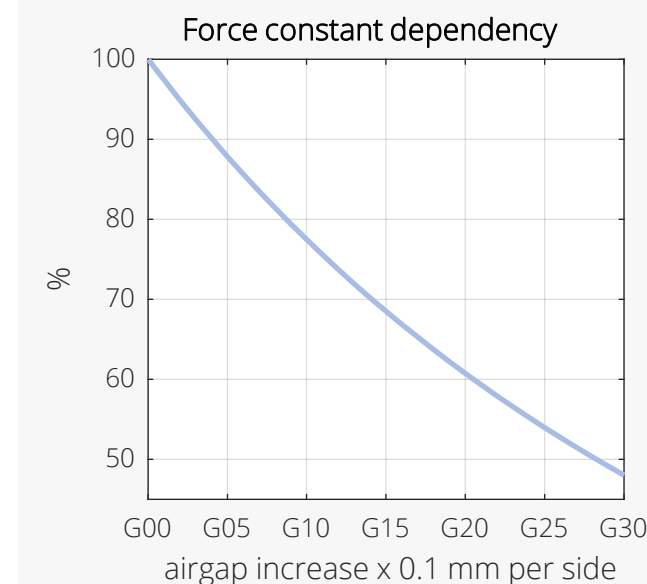

Airgap dependency

PHOENIX-S MECHANICAL SPECIFICATIONS

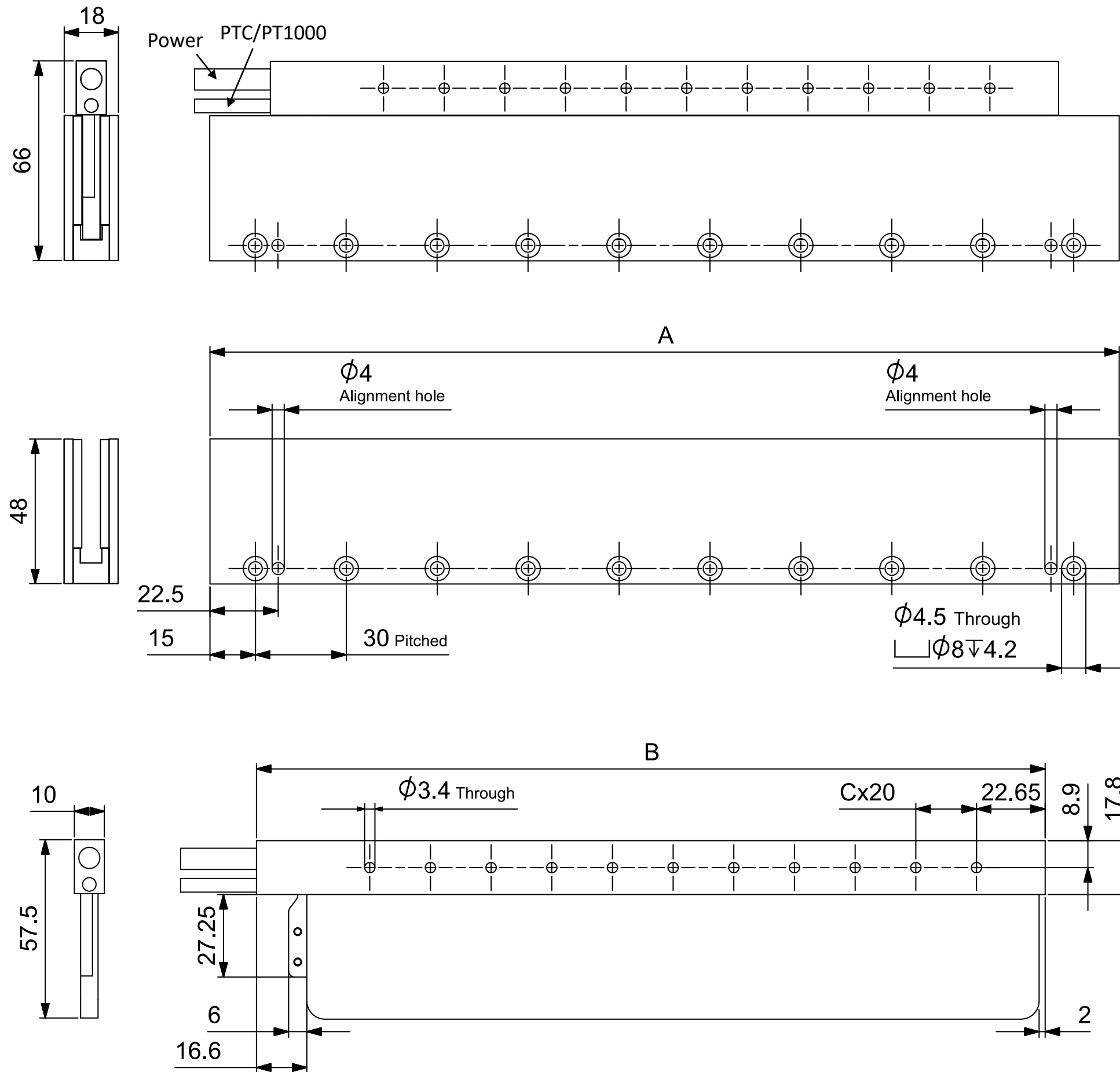

Magnet Yokes	Parameter	Symbol	Unit	MY-S-08	MY-S-10	MY-S-12	MY-S-20	MY-S-28
	Number of poles	N_p	-	8	10	12	20	28
	Pole pitch (N-N)	$2\tau_p$	mm	30	30	30	30	30
	Width	A	mm	120	150	180	300	420
Mass	M_{my}	kg	0.5	0.6	0.7	1.1	1.6	

Coil Units	Parameter	Symbol	Unit	CU-S-03	CU-S-06	CU-S-09	CU-S-12
	Number of coils	N_{coil}	-	3	6	9	12
	Coil pitch	τ_{coil}	mm	20	20	20	20
	Width	B	mm	80	140	200	260
	Number of hole pitches	C	-	1	4	7	10
	Mass (ex. cable)	M_{cu}	kg	0.13	0.20	0.26	0.33
Standard cable length	L_{cable}	m	1	1	1	1	

PHOENIX-M PERFORMANCE SPECIFICATIONS

Parameter	Symbol	Unit	T _{coil} (°C)	CU-M-03		CU-M-06			CU-M-09				CU-M-12				CU-M-15			
				C	D	A	B	C	A	B	C	D	A	B	C	D	A	B	C	D
Winding configuration	-	-	-	C D		A B C			A B C D				A B C D				A B C D			
Peak force ($\alpha_T = 20^\circ\text{C/s}$ increase)	F _p	N	20	300		650			950 750 950				1250 750 1250				1600 750 1550			
Continuous force, interface at 20°C	F _c	N	100	70		140			210				270				340			
Attraction force (I = 0)	F _{att}	N	-	0		0			0				0				0			
Motor constant	S	N ² /W	20	100		200			300				400				500			
Force constant	K _f	N/A _{rms}	-	63	32	63	32	125	63	32	188	95	63	32	251	126	63	32	314	158
Maximum velocity (F = 0)	v _m	m/s	-	7.8	16	7.8	16	3.9	7.8	16	2.6	5.2	7.8	16	2.0	3.9	7.8	16	1.6	3.1
Maximum velocity (F = F _p)	v _i	m/s	20	4.5	12	4.5	12	0.7	4.5	12	0.0	2.0	4.5	12	0.0	0.7	4.5	12	0.0	0.0
Maximum dc bus voltage	V _{dc}	V	-	400		400			400				400				400			
Phase resistance	R _{ph,20}	Ohm	20	13	3.3	6.6	1.6	27	4.4	1.1	40	10	3.3	0.8	53	13	2.7	0.7	66	16
Phase inductance	L _{ph}	mH	20	8.3	2.1	4.1	1.0	17	2.8	0.7	25	6.3	2.1	0.5	33	8.4	1.7	0.4	41	10
Peak line emf constant	K _{e,ll,p}	Vs/m	-	51	26	51	26	102	51	26	154	77	51	26	205	103	51	26	256	129
Maximum rms current	I _p	A _{rms}	20	5.0	10	10	20	5.0	15	30	4.1	10	20	40	3.1	10	25	50	2.5	10
Continuous rms current, interface at 20°C	I _c	A _{rms}	100	1.1	2.2	2.2	4.4	1.1	3.3	6.6	1.1	2.2	4.4	8.8	1.1	2.2	5.4	11	1.1	2.2
Continuous dissipation, interface at 20°C	P _{d,c}	W	100	62		124			186				247				309			
Thermal resistance, coils to interface	R _{th,i}	K/W	-	1.3		0.65			0.43				0.32				0.26			
Thermal resistance, coils to conv. surface	R _{th,c}	K/W	-	0.098		0.049			0.033				0.024				0.020			
Thermal time constant, interface at 20°C	τ _{th}	s	-	160		160			160				160				160			

Notes

- Specifications are based upon a magnet temperature of 20°C
- Specifications consider complete overlap of coil unit/magnet yoke
- Specifications consider sinusoidal q-axis commutation
- Velocity specifications are based on the maximum bus voltage
- Specifications consider a magnet yoke with nominal airgap (G00)
- See 'definitions' section at the end of the catalog for more details

Product marking / approvals



- Power Interface:**
- Phase U (L1)
 - Phase V (L2)
 - Phase W (L3)
 - PE (Green/Yellow)
- Thermal Interface (only N/B):**
- PT1000 (White)
 - PT1000 (Brown)
 - PTC (Green)
 - PTC (Yellow)

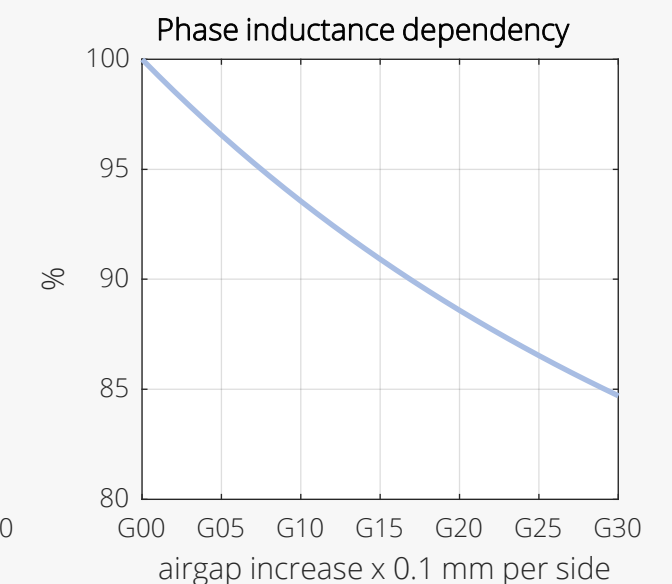
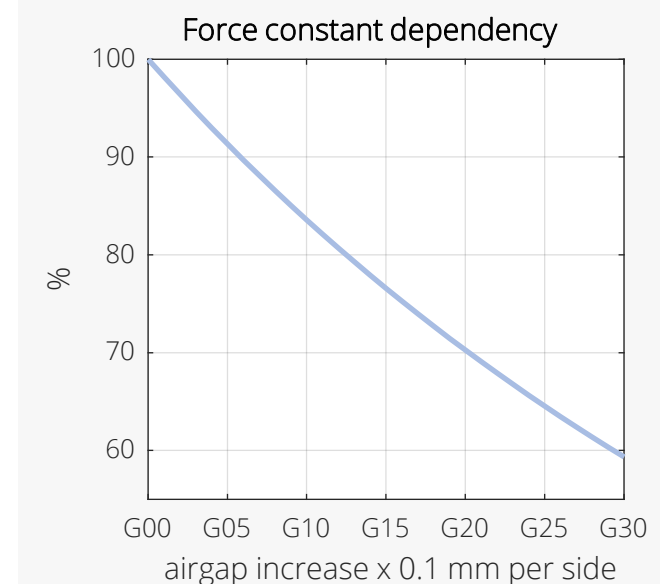

Electrical interfaces

Airgap dependency

PHOENIX-M MECHANICAL SPECIFICATIONS

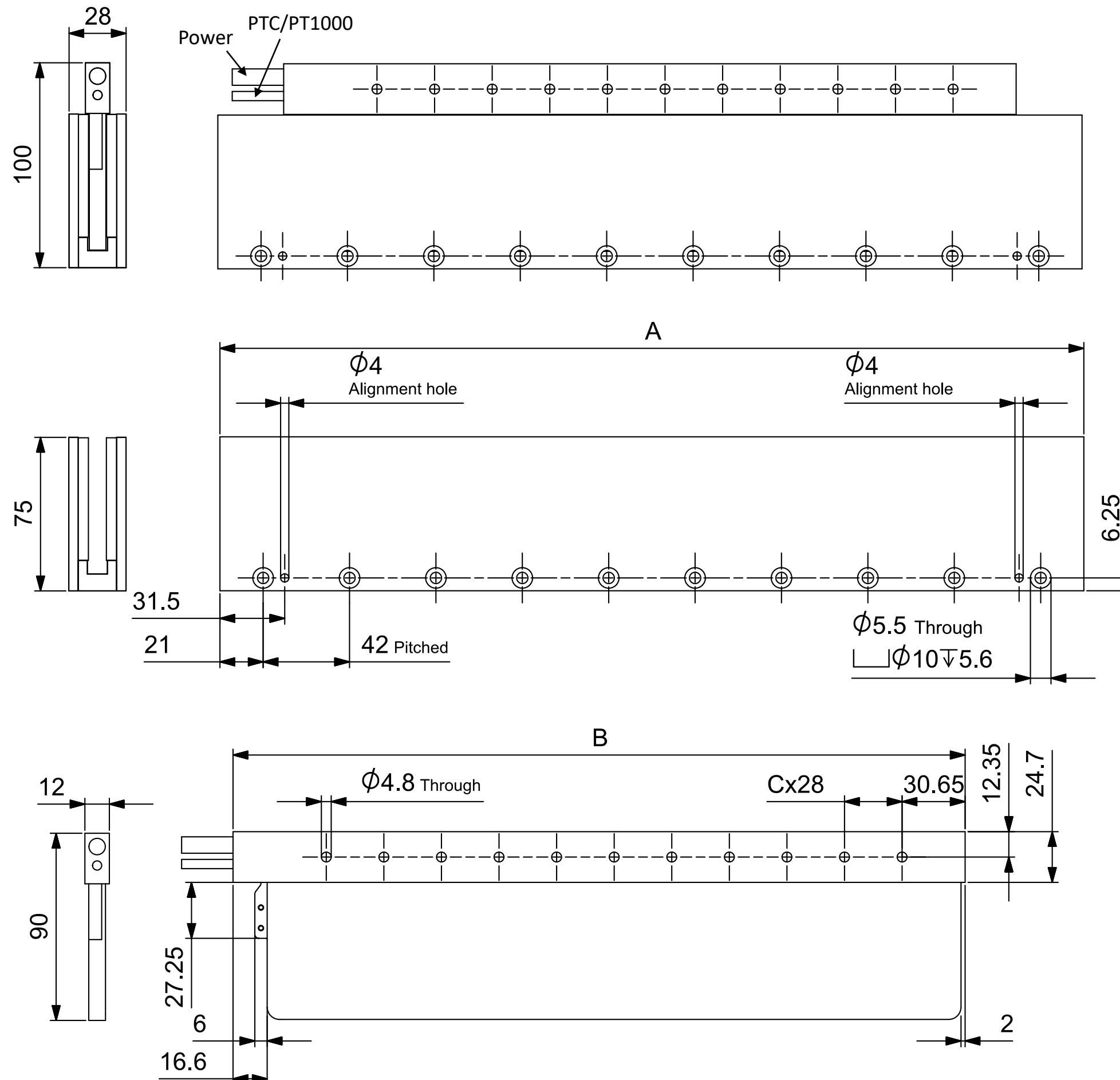

	Parameter	Symbol	Unit	MY-M-08	MY-M-10	MY-M-12	MY-M-20	MY-M-48
Magnet Yokes	Number of poles	N_p	-	8	10	12	20	48
	Pole pitch (N-N)	$2\tau_p$	mm	42	42	42	42	42
	Width	A	mm	168	210	252	420	1008
	Mass	M_{my}	kg	1.7	2.1	2.5	4.2	10.0

	Parameter	Symbol	Unit	CU-M-03	CU-M-06	CU-M-09	CU-M-12	CU-M-15
Coil Units	Number of coils	N_{coil}	-	3	6	9	12	15
	Coil pitch	τ_{coil}	mm	28	28	28	28	28
	Width	B	mm	104	188	272	356	440
	Number of hole pitches	C	-	1	4	7	10	13
	Mass (ex. cable)	M_{cu}	kg	0.31	0.51	0.71	0.9	1.1
	Standard cable length	L_{cable}	m	1	1	1	1	1

PHOENIX-L PERFORMANCE SPECIFICATIONS

Parameter	Symbol	Unit	T _{coil} (°C)	CU-L-03		CU-L-06			CU-L-09				CU-L-12			CU-L-15			CU-L-18																										
				C	D	A	B	C	A	B	C	D	A	C	D	A	C	D	A	C	D																								
Winding configuration	-	-	-	C D		A B C			A B C D				A C D			A C D																													
Peak force ($\alpha_f = 20^\circ\text{C/s}$ increase)	F _p	N	20	700		1350			2050				1850			2050			2700			1850			2700			3400			1850			3400			4050			1850			4050		
Continuous force, interface at 20°C	F _c	N	100	125		245			370				490			615			735																										
Attraction force (I = 0)	F _{att}	N	-	0		0			0				0			0			0																										
Motor constant	S	N ² /W	20	230		460			700				930			1160			1390																										
Force constant	K _f	N/A _{rms}	-	107	48	107	48	214	107	48	321	145	107	428	193	107	535	241	107	641	289																								
Maximum velocity (F = 0)	v _m	m/s	-	7.9	18	7.9	18	4.0	7.9	18	2.6	5.8	7.9	2.0	4.4	7.9	1.6	3.5	7.9	1.3	2.9																								
Maximum velocity (F = F _p)	v _i	m/s	20	4.8	13.9	4.8	14	1.0	4.8	14	0.0	2.8	4.8	0.0	1.4	4.8	0.0	0.6	4.8	0.0	0.0																								
Maximum dc bus voltage	V _{dc}	V	-	690		690			690				690			690			690																										
Phase resistance	R _{ph,20}	Ohm	20	16	3.3	8.2	1.7	33	5.5	1.1	49	10	4.1	66	13	3.3	82	17	2.7	99	20																								
Phase inductance	L _{ph}	mH	20	18	3.6	8.9	1.8	35	5.9	1.2	53	11	4.4	71	14	3.5	89	18	3.0	106	22																								
Peak line emf constant	K _{e,ll,p}	Vs/m	-	87	39	87	39	175	87	39	262	118	87	349	157	87	436	197	87	524	236																								
Maximum rms current	I _p	A _{rms}	20	6.3	14	13	28	6.3	19	42	5.7	14	25	4.3	14	32	3.4	14	38	2.9	14																								
Continuous rms current, interface at 20°C	I _c	A _{rms}	100	1.1	2.5	2.3	5.1	1.1	3.4	7.6	1.1	2.5	4.6	1.1	2.5	5.7	1.1	2.5	6.9	1.1	2.5																								
Continuous dissipation, interface at 20°C	P _{d,c}	W	100	85		170			254				339			424			509																										
Thermal resistance, coils to interface	R _{th,i}	K/W	-	0.94		0.47			0.31				0.24			0.19			0.16																										
Thermal resistance, coils to conv. surface	R _{th,c}	K/W	-	0.067		0.033			0.022				0.017			0.013			0.011																										
Thermal time constant, interface at 20°C	τ _{th}	s	-	180		180			180				180			180			180																										

Notes

- Specifications are based upon a magnet temperature of 20°C
- Specifications consider complete overlap of coil unit/magnet yoke
- Specifications consider sinusoidal q-axis commutation
- Velocity specifications are based on the maximum bus voltage
- Specifications consider a magnet yoke with nominal airgap (G00)
- See 'definitions' section at the end of the catalog for more details

Product marking / approvals



- Power Interface:**
- Phase U (L1)
 - Phase V (L2)
 - Phase W (L3)
 - PE (Green/Yellow)
- Thermal Interface (only N/B):**
- PT1000 (White)
 - PT1000 (Brown)
 - PTC (Green)
 - PTC (Yellow)

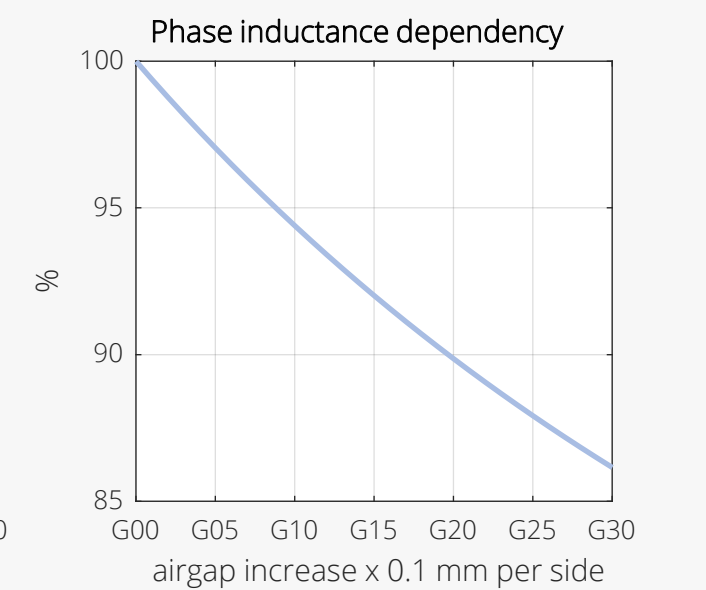
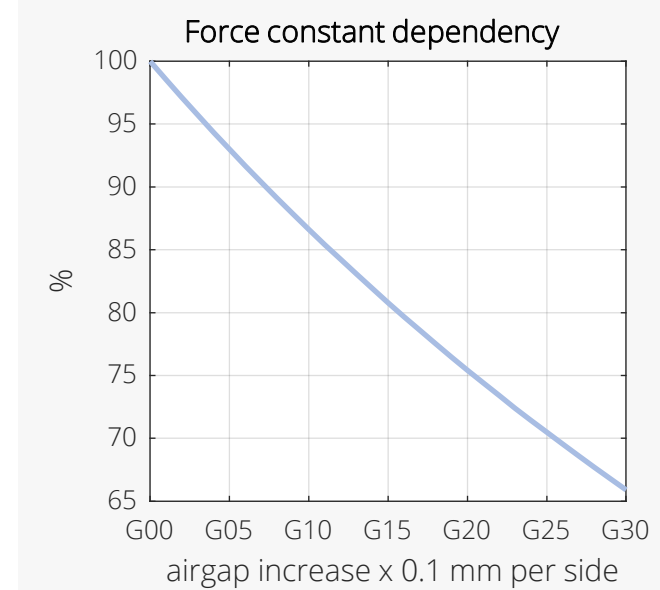

Electrical interfaces

Airgap dependency

PHOENIX-L MECHANICAL SPECIFICATIONS

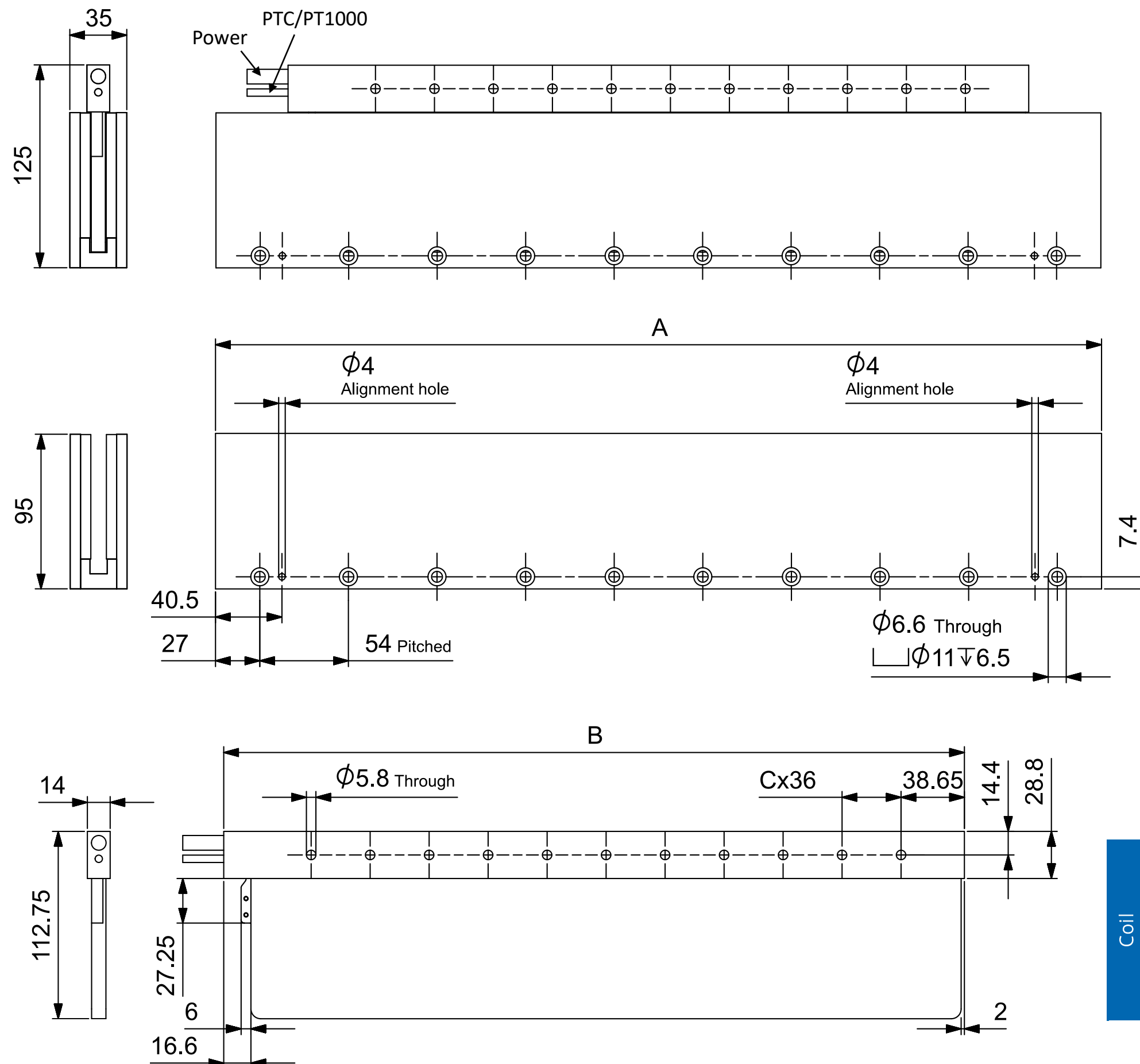

	Parameter	Symbol	Unit	MY-L-08	MY-L-10	MY-L-12	MY-L-20	MY-L-36
Magnet Yokes	Number of poles	N_p	-	8	10	12	20	36
	Pole pitch (N-N)	$2\tau_p$	mm	54	54	54	54	54
	Width	A	mm	216	270	324	540	972
	Mass	M_{my}	kg	3.6	4.5	5.4	9.0	16.1

	Parameter	Symbol	Unit	CU-L-03	CU-L-06	CU-L-09	CU-L-12	CU-L-15	CU-L-18
Coil Units	Number of coils	N_{coil}	-	3	6	9	12	15	18
	Coil pitch	τ_{coil}	mm	36	36	36	36	36	36
	Width	B	mm	128	236	344	452	560	668
	Number of hole pitches	C	-	1	4	7	10	13	16
	Mass (ex. cable)	M_{cu}	kg	0.52	0.9	1.3	1.7	2.1	2.4
	Standard cable length	L_{cable}	m	1	1	1	1	1	1

PHOENIX-X PERFORMANCE SPECIFICATIONS

Parameter	Symbol	Unit	T _{coil} (°C)	CU-X-03		CU-X-06			CU-X-09				CU-X-12				CU-X-15				CU-X-18		
				C	D	A	B	C	A	B	C	D	A	B	C	D	A	B	C	D	A	C	D
Winding configuration	-	-	-	C D		A B C			A B C D				A B C D				A B C D				A C D		
Peak force (α _r = 20°C/s increase)	F _p	N	20	1600		3250			4850 3500 4800				6450 3500 6400				8050 3500 7850				6600 5700 5600		
Continuous force, interface at 20°C	F _c	N	100	215		430			645				860				1075				1295		
Attraction force (I = 0)	F _{att}	N	-	0		0			0				0				0				0		
Motor constant	S	N ² /W	20	590		1190			1780				2370				2960				3570		
Force constant	K _f	N/A _{rms}	-	144	63	144	63	288	144	63	433	189	144	63	577	252	144	63	721	315	144	865	378
Maximum velocity (F = 0)	v _m	m/s	-	5.9	13	5.9	13	2.9	5.9	13	2.0	4.5	5.9	13	1.5	3.4	5.9	13	1.2	2.7	5.9	1.0	2.2
Maximum velocity (F = F _p)	v _i	m/s	20	3.0	10	3.0	10	0.2	3.0	10	0.0	1.7	3.0	10	0.0	0.6	3.0	10	0.0	0.0	3.0	0.0	0.0
Maximum dc bus voltage	V _{dc}	V	-	690		690			690				690				690				690		
Phase resistance	R _{ph,20}	Ohm	20	11.6	2.3	5.8	1.1	23	3.9	0.8	35	6.8	2.9	0.6	46	9.0	2.3	0.5	58	11	1.9	69	14
Phase inductance	L _{ph}	mH	20	21	4.0	10.5	2.0	42	7.0	1.3	63	12	5.3	1.0	84	16	4.2	0.8	105	20	3.5	126	24
Peak line emf constant	K _{e,ll,p}	Vs/m	-	118	51	118	51	235	118	51	353	154	118	51	471	206	118	51	589	257	118	706	309
Maximum rms current	I _p	A _{rms}	20	11	25	22	51	11	34	76	8	25	45	102	6.1	25	56	127	4.9	25	67	4.1	21
Continuous rms current, interface at 20°C	I _c	A _{rms}	100	1.5	3.4	3.0	6.8	1.5	4.5	10	1.5	3.4	6.0	14	1.5	3.4	7.5	17	1.5	3.4	9	1.5	3.4
Continuous dissipation, interface at 20°C	P _{d,c}	W	100	103		205			308				410				513				615		
Thermal resistance, coils to interface	R _{th,i}	K/W	-	0.78		0.39			0.26				0.20				0.16				0.13		
Thermal resistance, coils to conv. surface	R _{th,c}	K/W	-	0.046		0.023			0.015				0.012				0.0092				0.0077		
Thermal time constant, interface at 20°C	τ _{th}	s	-	320		320			320				320				320				320		

Notes

- Specifications are based upon a magnet temperature of 20°C
- Specifications consider complete overlap of coil unit/magnet yoke
- Specifications consider sinusoidal q-axis commutation
- Velocity specifications are based on the maximum bus voltage
- Specifications consider a magnet yoke with nominal airgap (G00)
- See 'definitions' section at the end of the catalog for more details

Product marking / approvals



- Power Interface:**
- Phase U (L1)
 - Phase V (L2)
 - Phase W (L3)
 - PE (Green/Yellow)
- Thermal Interface (only N/B):**
- PT1000 (White)
 - PT1000 (Brown)
 - PTC (Green)
 - PTC (Yellow)

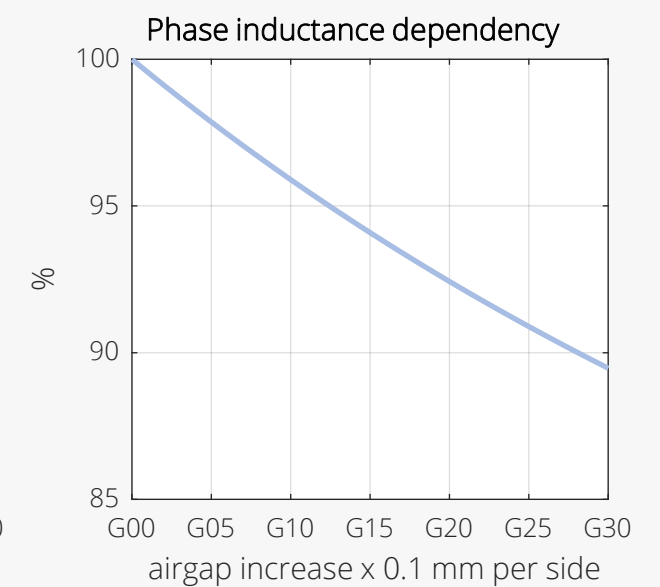
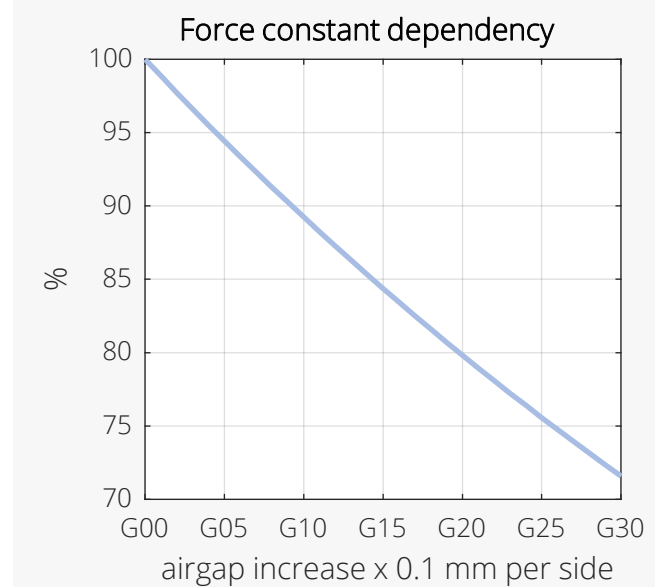

Electrical interfaces

Airgap dependency

PHOENIX-X MECHANICAL SPECIFICATIONS

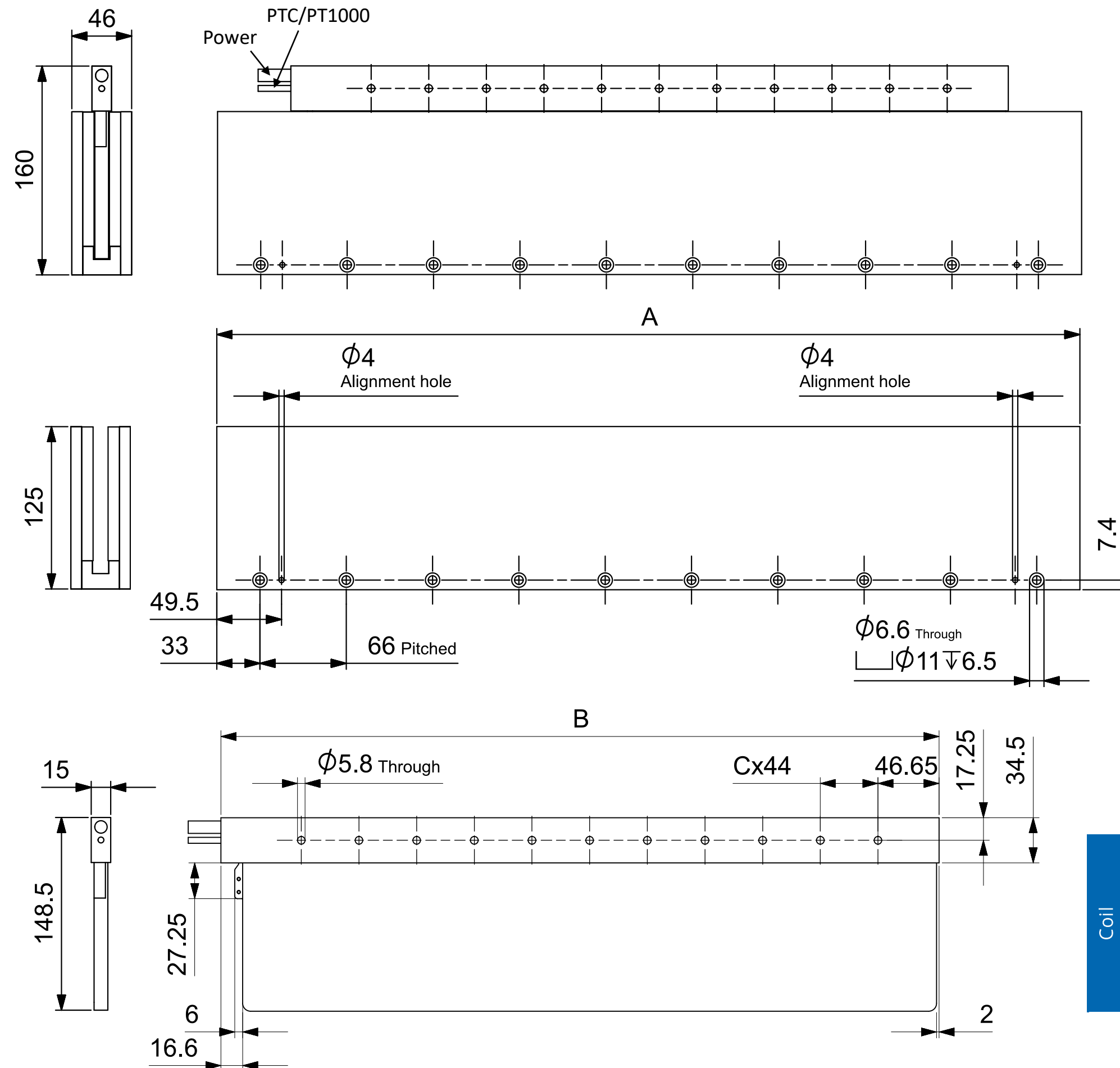

Magnet Yokes	Parameter	Symbol	Unit	MY-X-08	MY-X-10	MY-X-12	MY-X-20
	Number of poles	N_p	-	8	10	12	20
	Pole pitch (N-N)	$2\tau_p$	mm	66	66	66	66
	Width	A	mm	264	330	396	660
	Mass	M_{my}	kg	7.7	9.6	11.5	19.2

Coil Units	Parameter	Symbol	Unit	CU-X-03	CU-X-06	CU-X-09	CU-X-12	CU-X-15	CU-X-18
	Number of coils	N_{coil}	-	3	6	9	12	15	18
	Coil pitch	τ_{coil}	mm	44	44	44	44	44	44
	Width	B	mm	152	284	416	548	680	812
	Number of hole pitches	C	-	1	4	7	10	13	16
	Mass (ex. cable)	M_{cu}	kg	0.9	1.7	2.5	3.2	4.0	4.8
Standard cable length	L_{cable}	m	1	1	1	1	1	1	

PHOENIX-U PERFORMANCE SPECIFICATIONS

	Parameter	Symbol	Unit	T _{coil} (°C)	CU-U-03		CU-U-06			CU-U-09				CU-U-12			CU-U-15			CU-U-18																													
					C	D	A	B	C	A	B	C	D	A	C	D	A	C	D	A	C	D																											
Electromechanical	Winding configuration	-	-	-	C	D	A	B	C	A	B	C	D	A	C	D	A	C	D	A	C	D																											
	Peak force ($\alpha_r = 20^\circ\text{C/s}$ increase)	F _p	N	20	3350		6650			5800				10000			5800			9950			13450			5800			10650			16800			5800			10650			20150			5800			10650		
	Continuous force, interface at 20°C	F _c	N	100	330		670			1000				1340			1670			2010																													
	Attraction force (I = 0)	F _{att}	N	-	0		0			0				0			0			0																													
	Motor constant	S	N ² /W	20	1150		2350			3500				4950			6400			6850																													
	Force constant	K _f	N/A _{rms}	-	171	91	171	91	342	171	91	513	272	171	684	363	171	856	454	171	1027	544																											
	Maximum velocity (F = 0)	v _m	m/s	-	4.9	9.3	4.9	9.3	2.5	4.9	9.3	1.6	3.1	4.9	1.2	2.3	4.9	1.0	1.9	4.9	0.8	1.6																											
Maximum velocity (F = F _p)	v _i	m/s	20	1.9	5.6	1.9	5.6	0.0	1.9	5.6	0.0	0.2	1.9	0.0	0.0	1.9	0.0	0.0	1.9	0.0	0.0																												
Electrical	Maximum dc bus voltage	V _{dc}	V	-	690		690			690				690			690			690																													
	Phase resistance	R _{ph,20}	Ohm	20	8.3	2.4	4.2	1.2	17	2.8	0.8	25	7.2	2.1	33	9.6	1.7	42	12	1.4	50	14																											
	Phase inductance	L _{ph}	mH	20	25	6.9	12	3.5	49	8.2	2.3	74	21	6.2	99	28	4.9	124	35	4.1	148	42																											
	Peak line emf constant	K _{e,ll,p}	Vs/m	-	140	74	140	74	279	140	74	419	222	140	559	296	140	699	370	140	838	444																											
	Maximum rms current	I _p	A _{rms}	20	20	36	39	73	17	59	109	11	36	78	8.5	29.3	98	6.8	23	118	5.7	20																											
	Continuous rms current, interface at 20°C	I _c	A _{rms}	100	2.0	3.7	3.9	7.3	2.0	5.9	11	2.0	3.7	7.9	2.0	3.7	10	2.0	3.7	12	2.0	3.7																											
Thermal	Continuous dissipation, interface at 20°C	P _{d,c}	W	100	126		253			379				537			695			758																													
	Thermal resistance, coils to interface	R _{th,i}	K/W	-	0.63		0.32			0.21				0.15			0.12			0.11																													
	Thermal resistance, coils to conv. surface	R _{th,c}	K/W	-	0.036		0.018			0.012				0.0086			0.0066			0.0060																													
	Thermal time constant, interface at 20°C	τ _{th}	s	-	550		550			550				550			550			550																													

Notes

- Specifications are based upon a magnet temperature of 20°C
- Specifications consider complete overlap of coil unit/magnet yoke
- Specifications consider sinusoidal q-axis commutation
- Velocity specifications are based on the maximum bus voltage
- Specifications consider a magnet yoke with nominal airgap (G00)
- See 'definitions' section at the end of the catalog for more details

Product marking / approvals



- Power Interface:**
- Phase U (L1)
 - Phase V (L2)
 - Phase W (L3)
 - PE (Green/Yellow)
- Thermal Interface (only N/B):**
- PT1000 (White)
 - PT1000 (Brown)
 - PTC (Green)
 - PTC (Yellow)

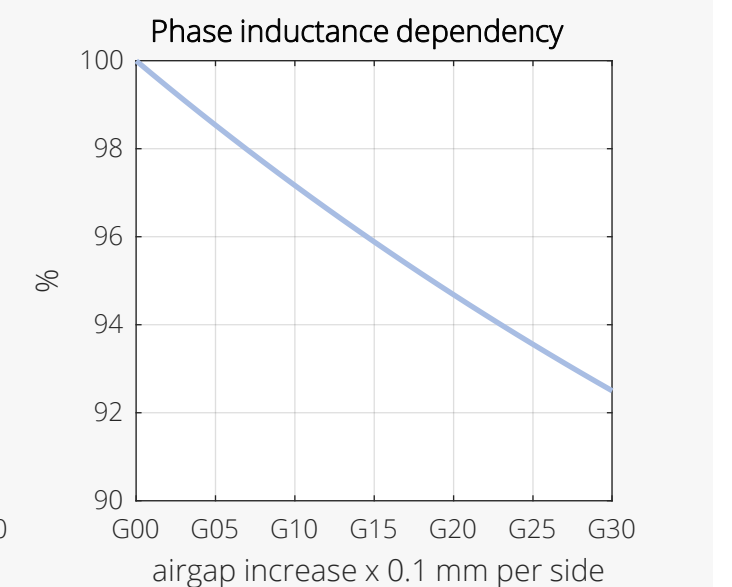
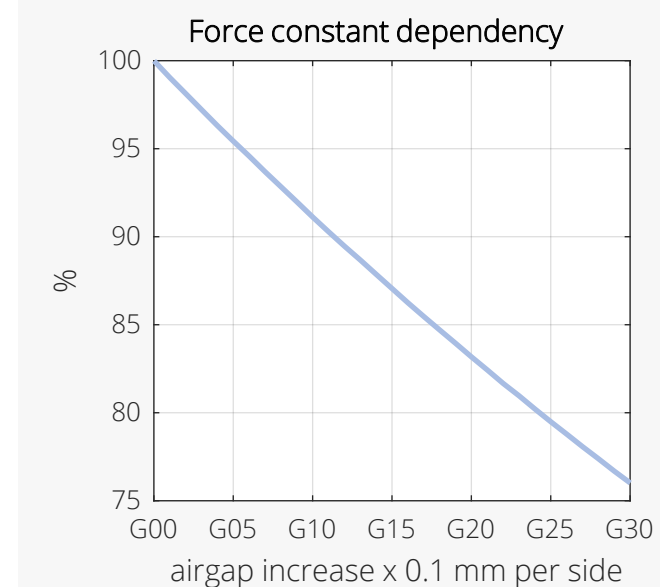

Electrical interfaces

Airgap dependency

PHOENIX-U MECHANICAL SPECIFICATIONS

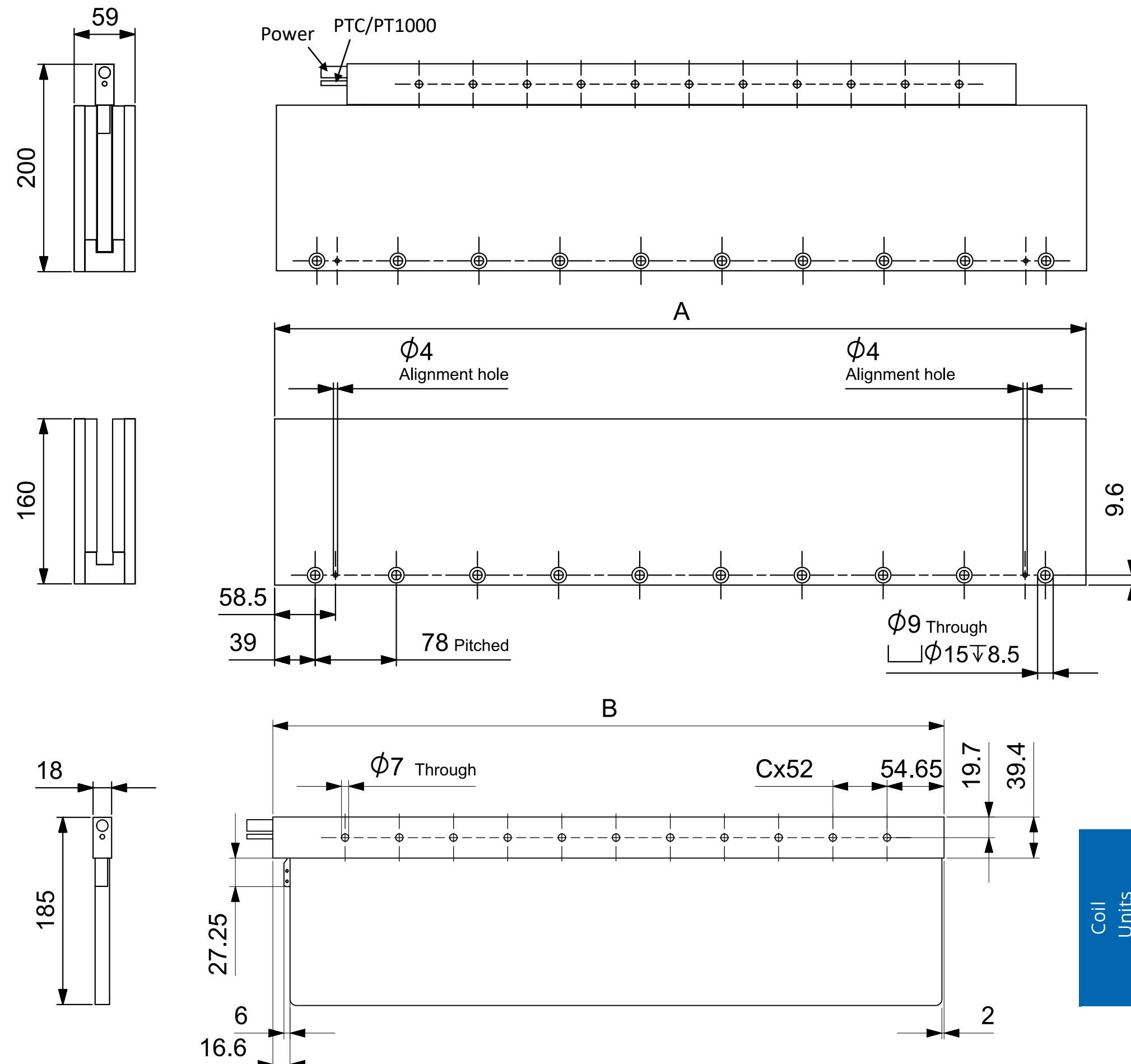

	Parameter	Symbol	Unit	MY-U-08	MY-U-10	MY-U-12	MY-U-18
Magnet Yokes	Number of poles	N_p	-	8	10	12	18
	Pole pitch (N-N)	$2\tau_p$	mm	78	78	78	78
	Width	A	mm	312	390	468	702
	Mass	M_{my}	kg	14.9	18.7	22.4	33.7

	Parameter	Symbol	Unit	CU-U-03	CU-U-06	CU-U-09	CU-U-12	CU-U-15	CU-U-18
Coil Units	Number of coils	N_{coil}	-	3	6	9	12	15	18
	Coil pitch	τ_{coil}	mm	52	52	52	52	52	52
	Width	B	mm	176	332	488	644	800	956
	Number of hole pitches	C	-	1	4	7	10	13	16
	Mass (ex. cable)	M_{cu}	kg	1.8	3.3	4.9	6.4	8.0	9.6
	Standard cable length	L_{cable}	m	1	1	1	1	1	1

PHOENIX-T/S FORCE-VELOCITY DIAGRAMS

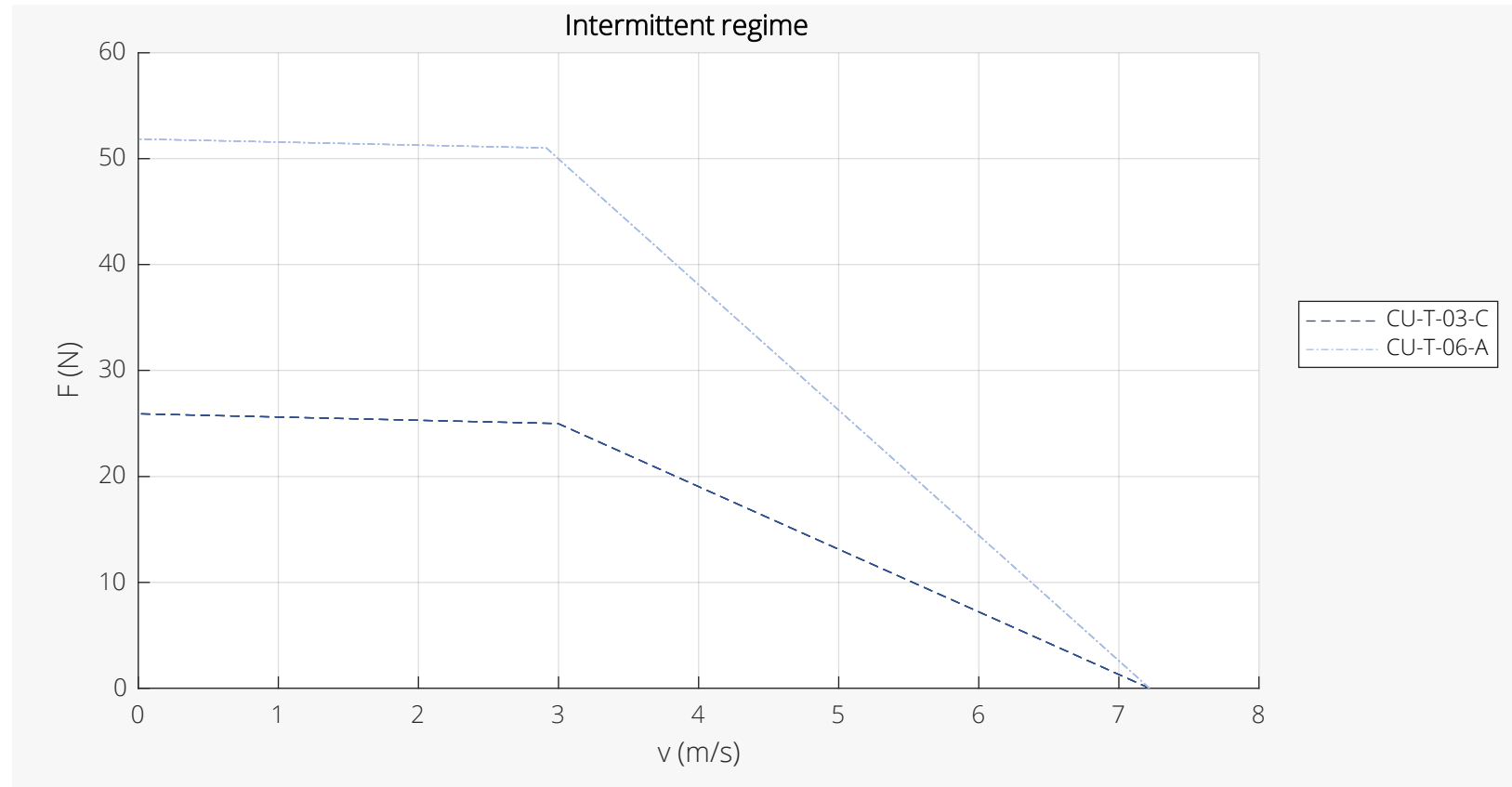

Force-Velocity Diagrams Size T Intermittent Regime

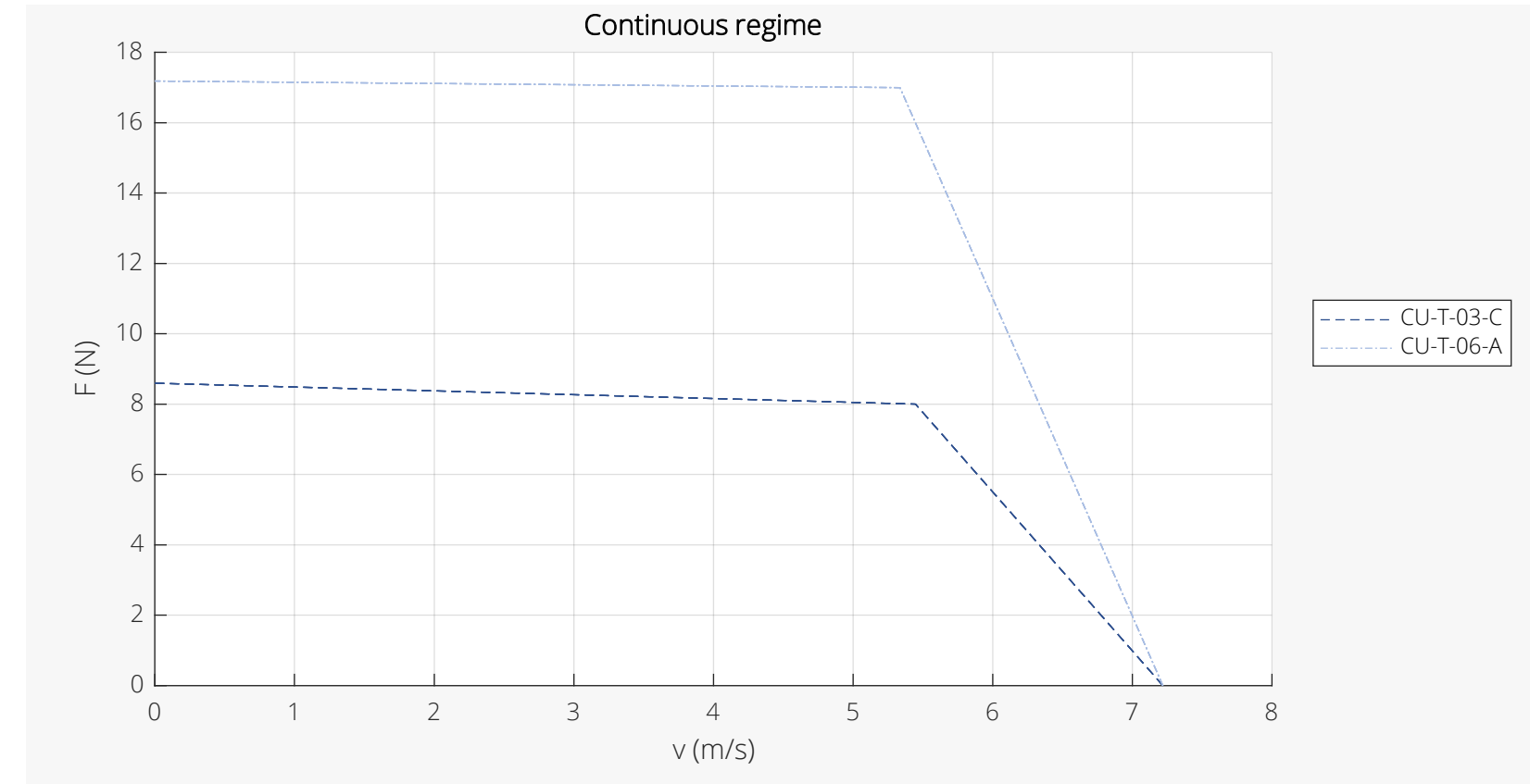

Force-Velocity Diagrams Size T Continuous Regime

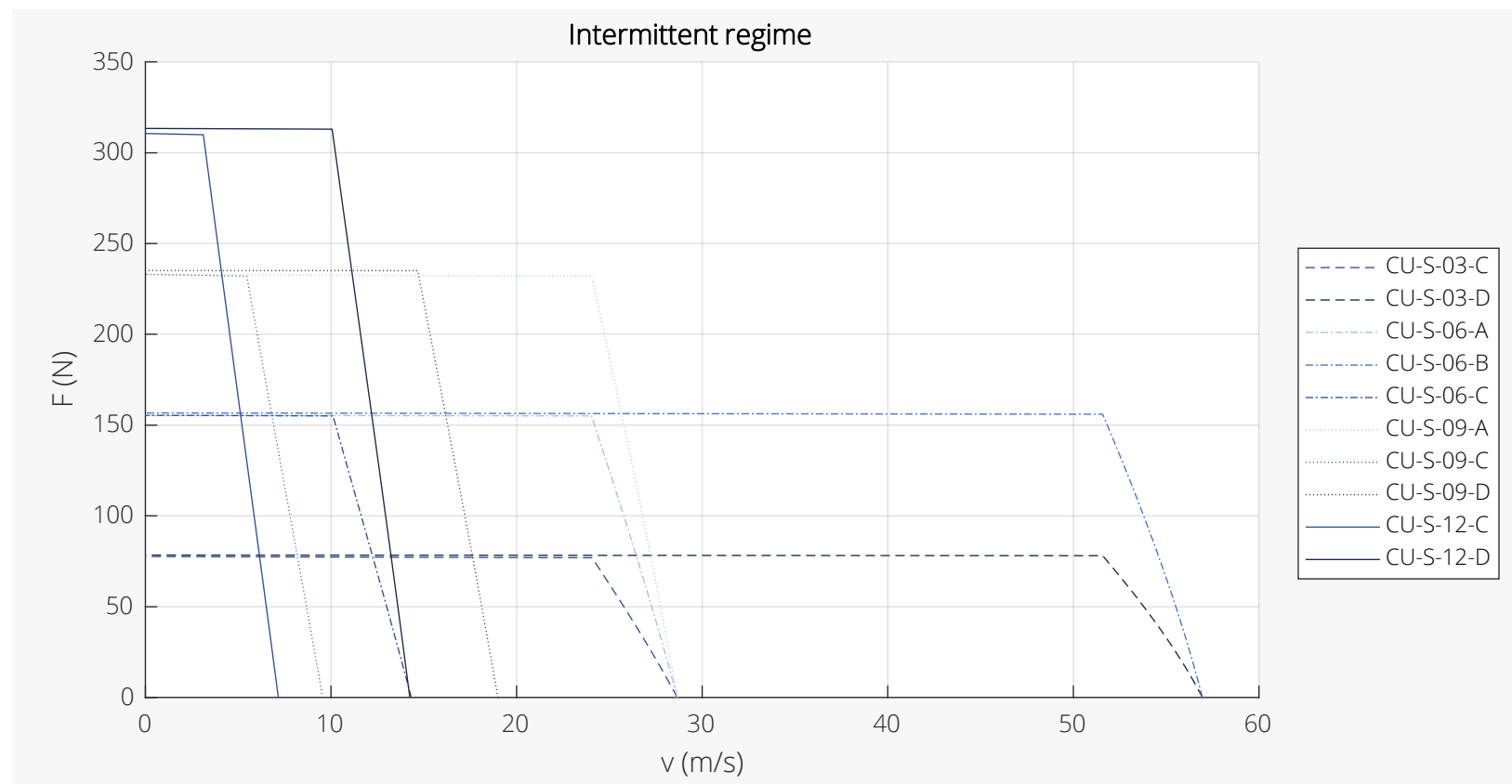

Force-Velocity Diagrams Size S Intermittent Regime

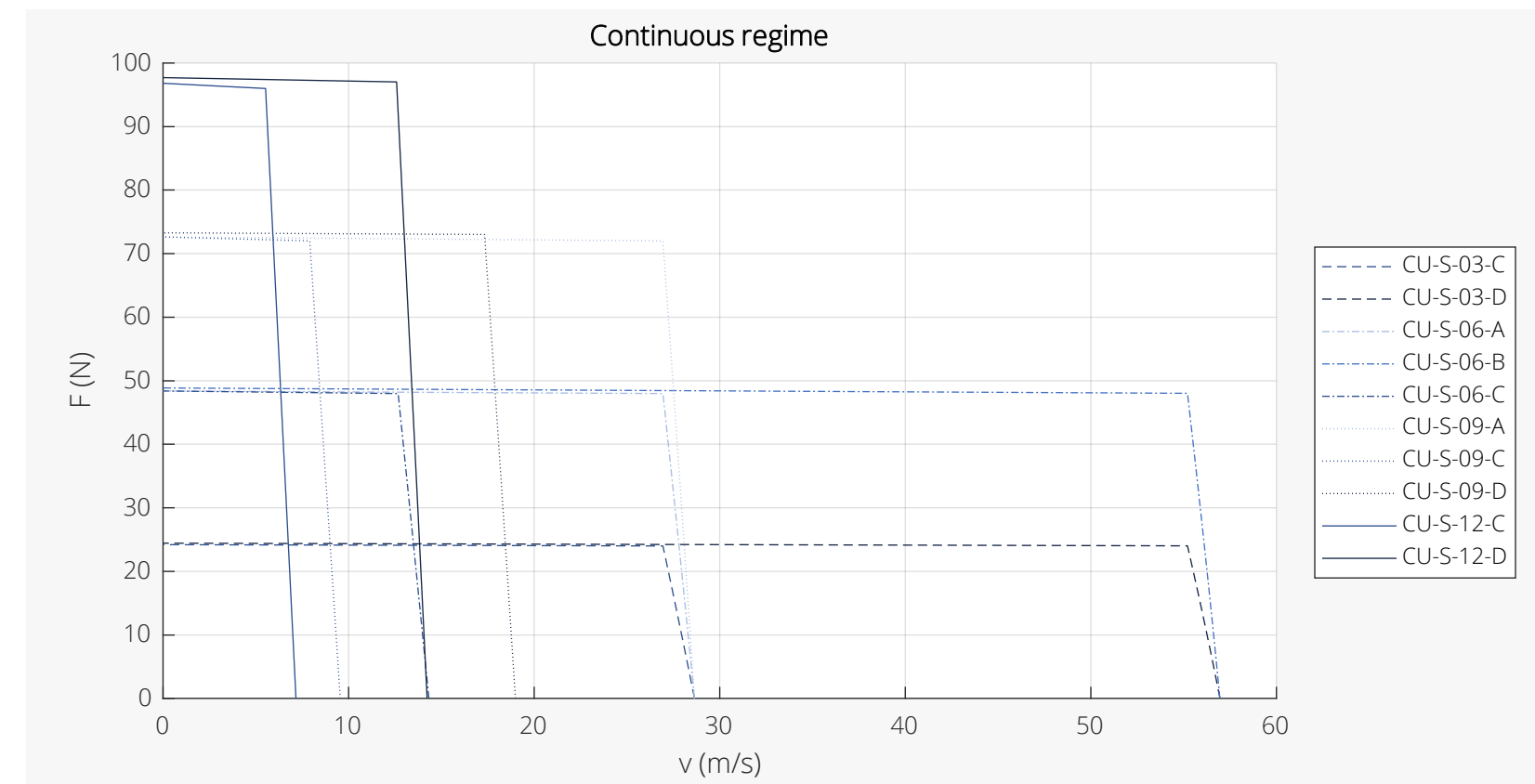

Force-Velocity Diagrams Size S Continuous Regime

PHOENIX-M/L FORCE-VELOCITY DIAGRAMS

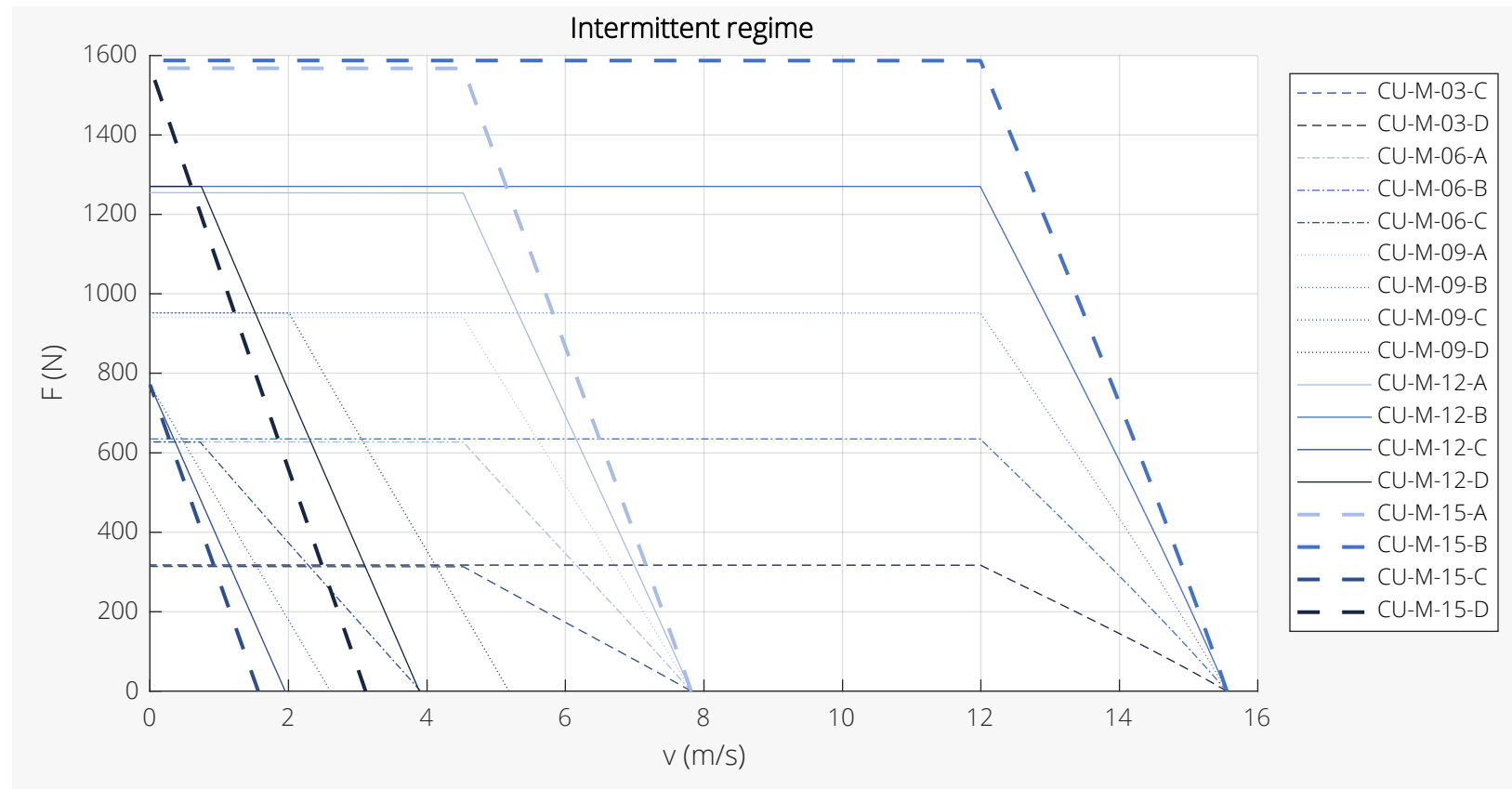

Force-Velocity Diagrams Size M Intermittent Regime

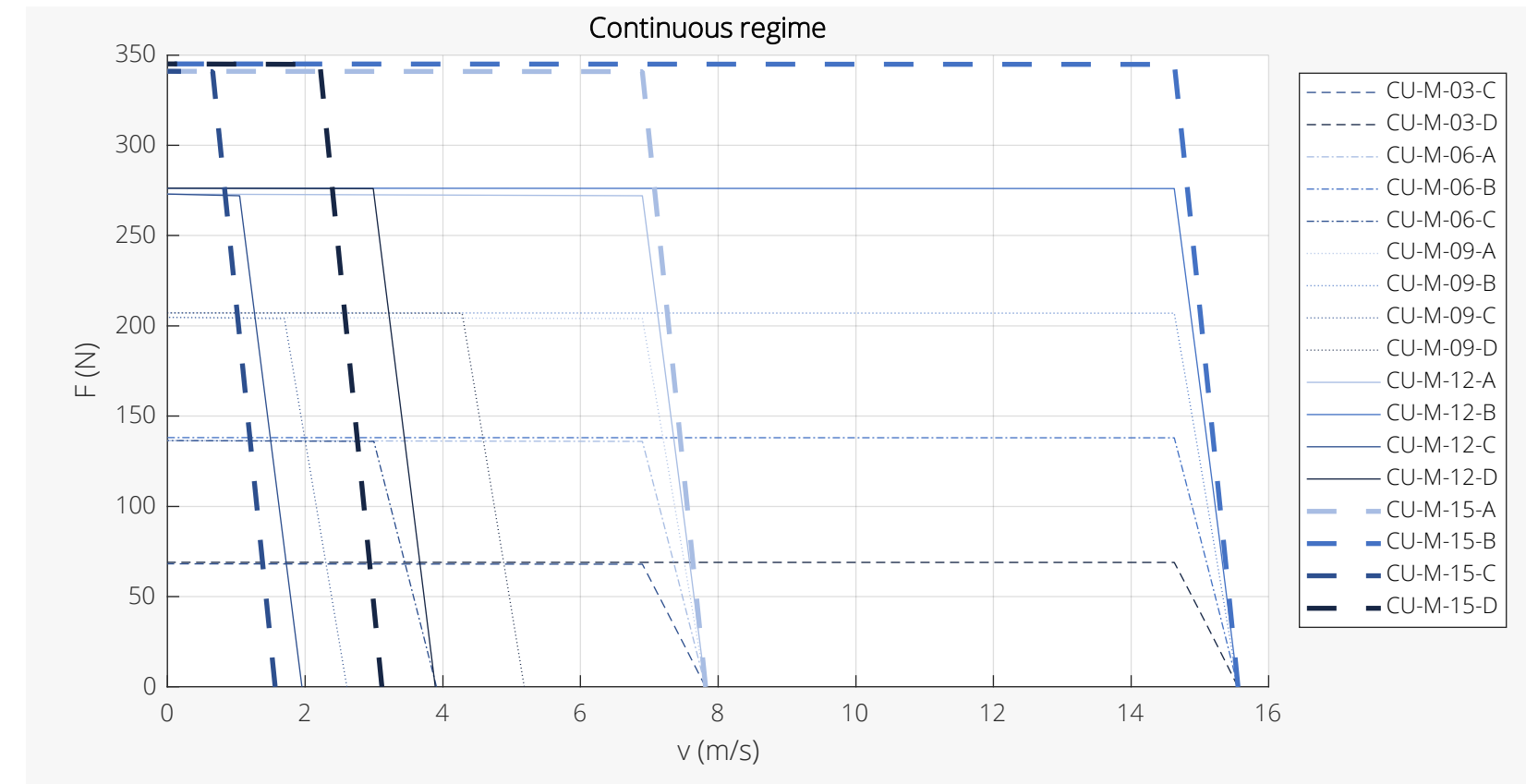

Force-Velocity Diagrams Size M Continuous Regime

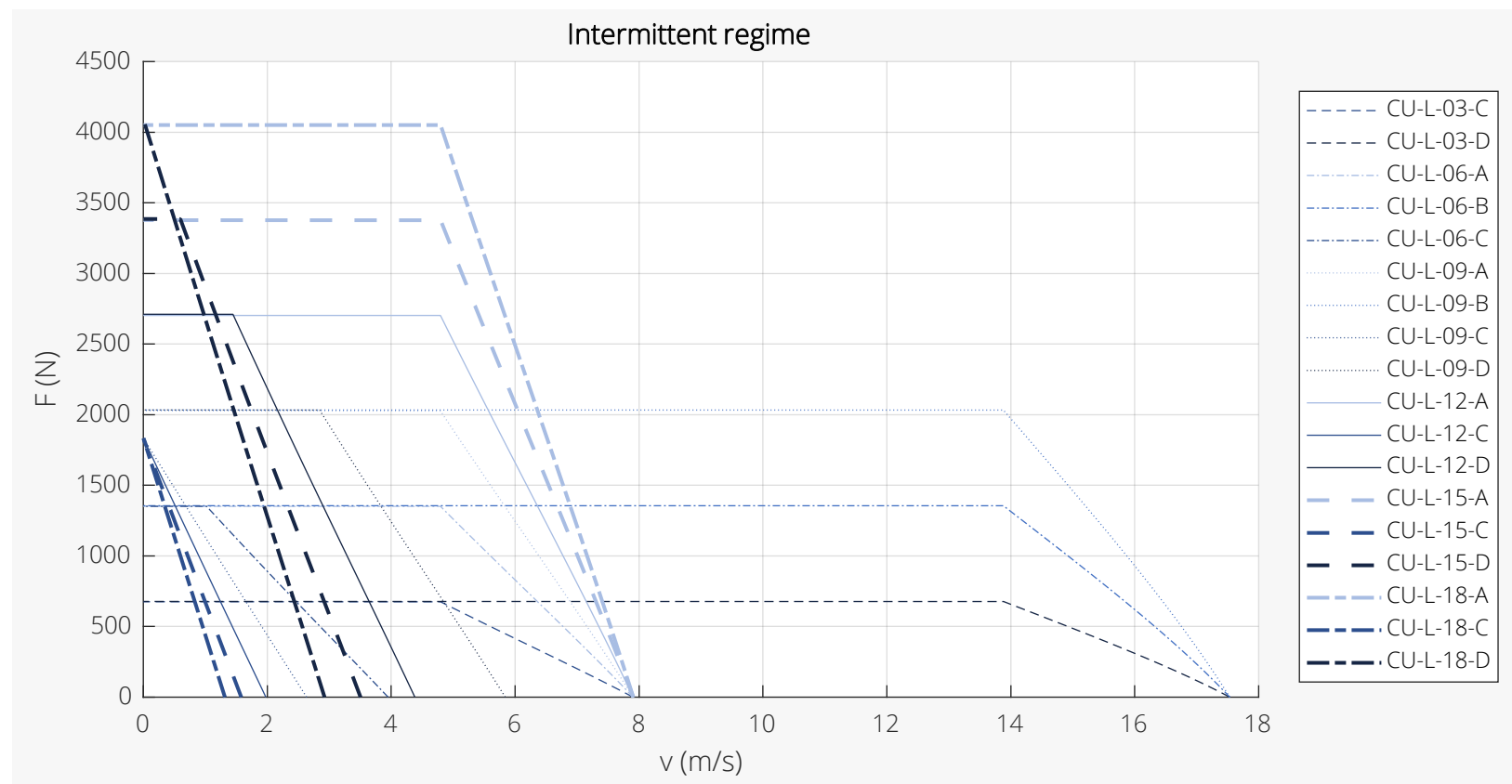

Force-Velocity Diagrams Size L Intermittent Regime

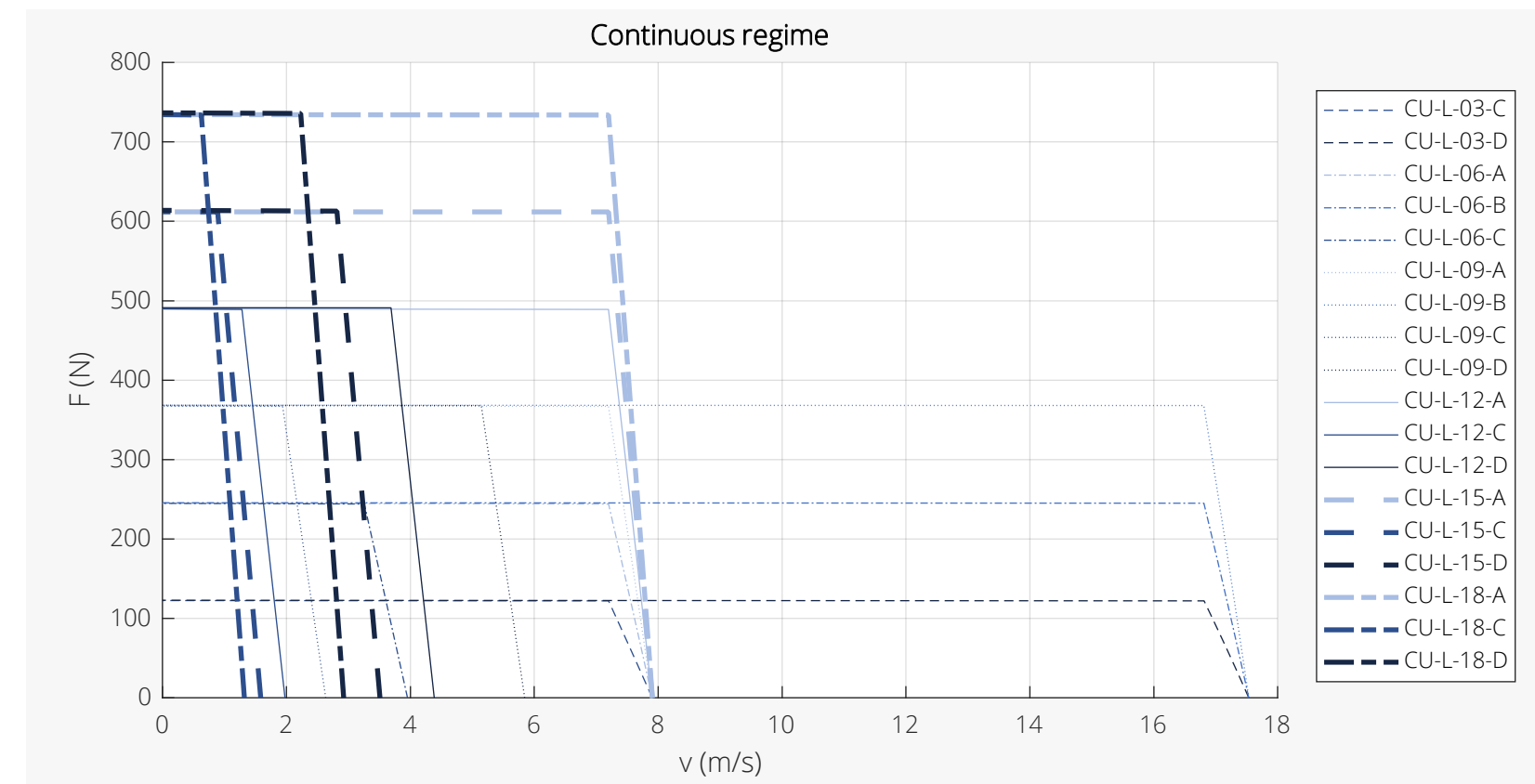

Force-Velocity Diagrams Size L Continuous Regime

PHOENIX-X/U FORCE-VELOCITY DIAGRAMS

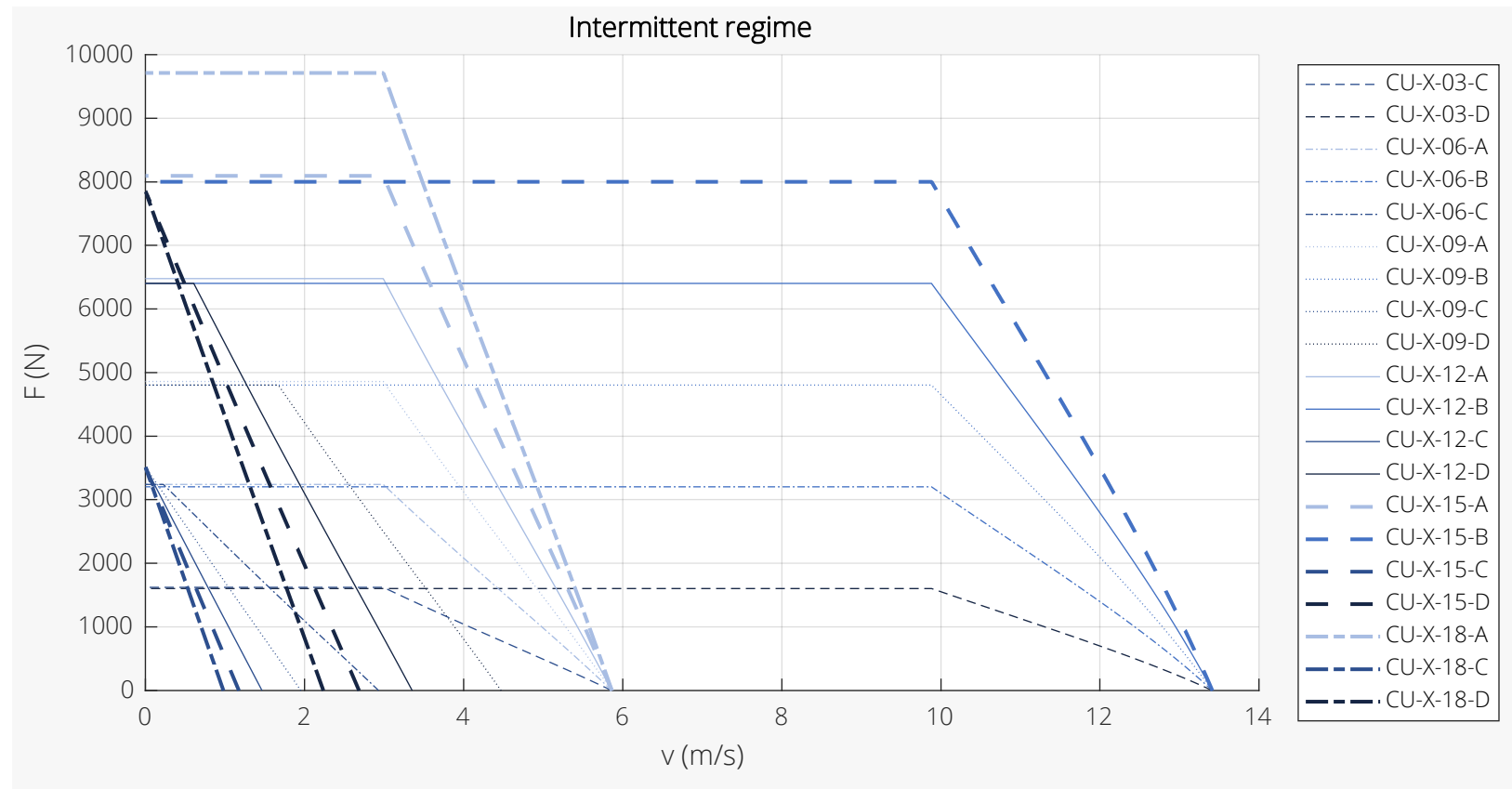

Force-Velocity Diagrams Size X Intermittent Regime

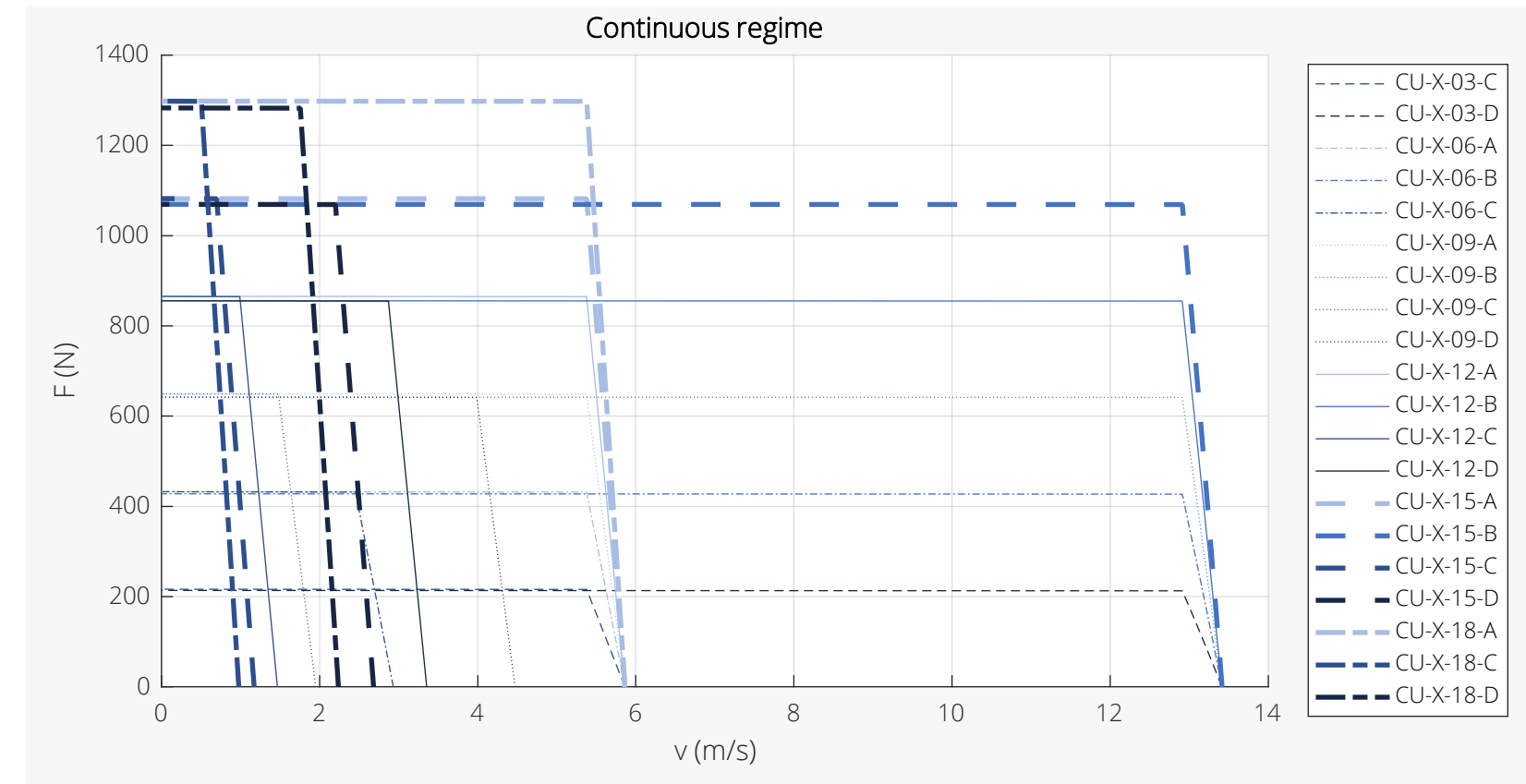

Force-Velocity Diagrams Size X Continuous Regime

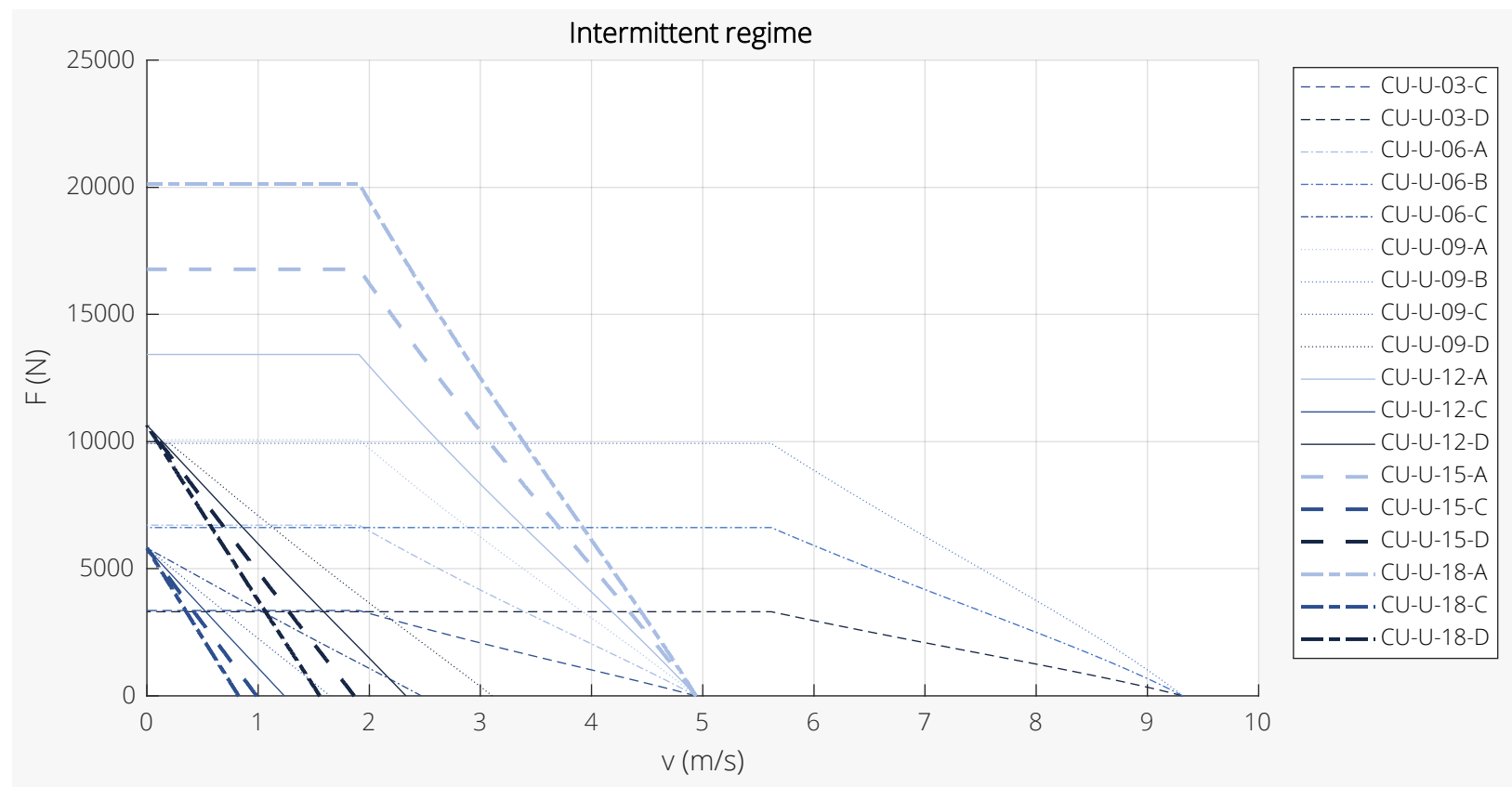

Force-Velocity Diagrams Size U Intermittent Regime

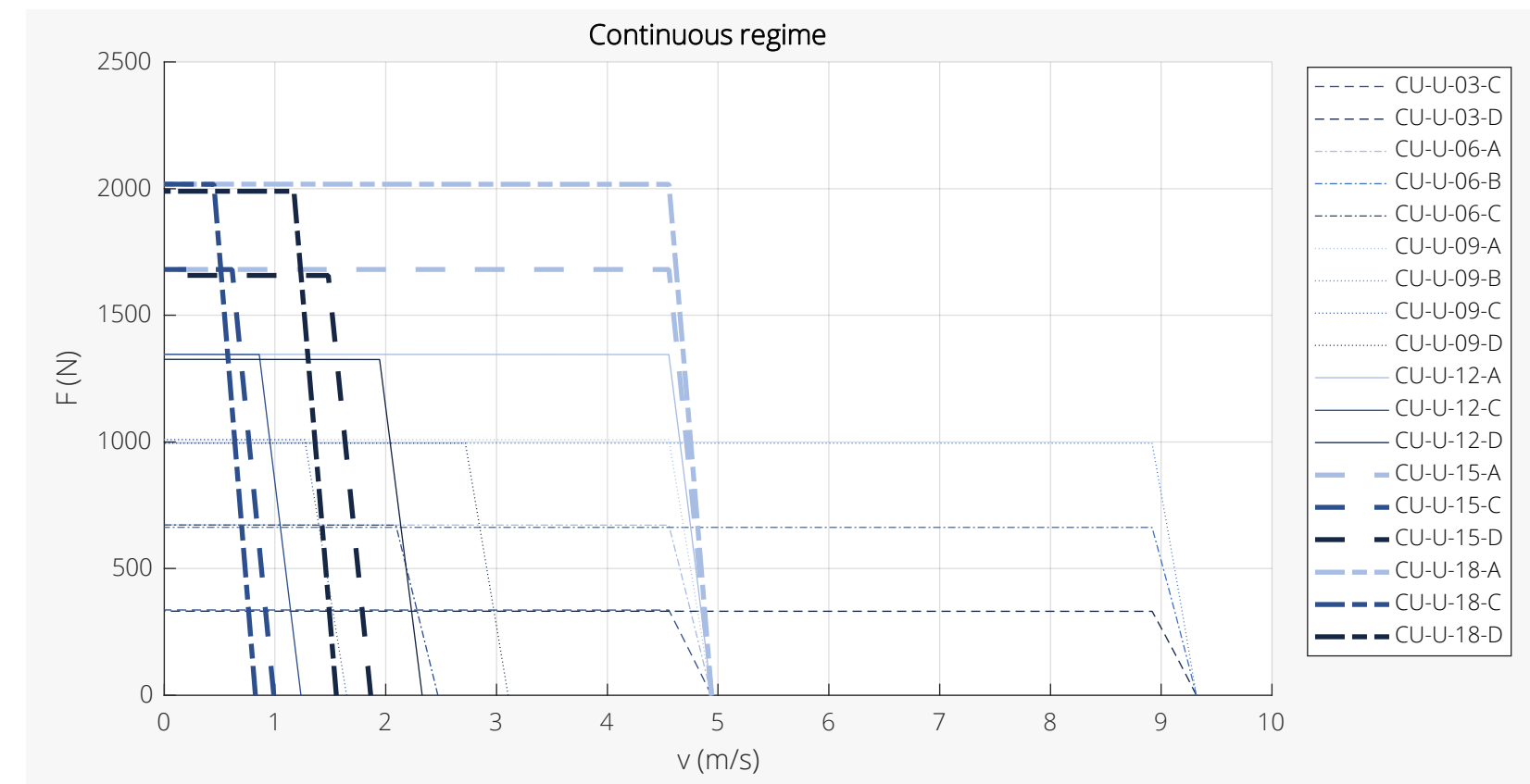

Force-Velocity Diagrams Size U Continuous Regime



- For correct operation of a linear motor, the commutation angle (the electrical angle between the coil unit and the magnet yoke) should be known. This commutation angle is needed to determine the phase angle of the three phase currents.
- The commutation angle can be derived from the relative displacement, for example using a position sensor. However, the Phoenix commutation sensor can directly measure the commutation angle without the need of a position sensor. The Phoenix commutation sensor can be directly attached to the coil unit which provides a cost-effective alternative to measure the commutation angle.
- The Phoenix commutation sensor contains three digital Hall sensors, each shifted by 120 electrical degrees, from which the commutation angle can be derived. Commutation sensors are available for each size of Phoenix (S/M/L/X/U).
- The commutation sensor allows a supply voltage range between 4.5 Vdc and 28 Vdc.

Phoenix-S commutation sensor (Phoenix-CS-S)

DEFINITIONS

Parameter	Symbol / Equation	Unit	Remarks
Coil temperature	T_{coil}	$^{\circ}C$	Average temperature over the complete coil volume
Interface temperature	T_{int}	$^{\circ}C$	Average temperature over the complete interface surface
Convective surface temperature	T_{conv}	$^{\circ}C$	Average temperature over the complete convective surface
Thermal resistance	$R_{th,i}$	K/W	From average coil temperature to average interface temperature
Thermal resistance	$R_{th,c}$	K/W	From average coil temperature to average convective surface temperature
Thermal time constant	τ_{th}	s	The time to reach 63.7% of the steady state temperature considering $T_{int} = 20^{\circ}C$

The actual continuous force is strongly dependent on the cooling conditions available in the application. Depending on the situation (vacuum environment, natural convection, forced convection or other), the thermal resistances of the coil unit ($R_{th,i}$ and $R_{th,c}$) should be combined with the thermal resistances of the cooling interfaces to determine the overall thermal resistance (R_{th}). This overall thermal resistance provides the maximum dissipated power and continuous force.

Please contact us for any support to calculate your specific application.

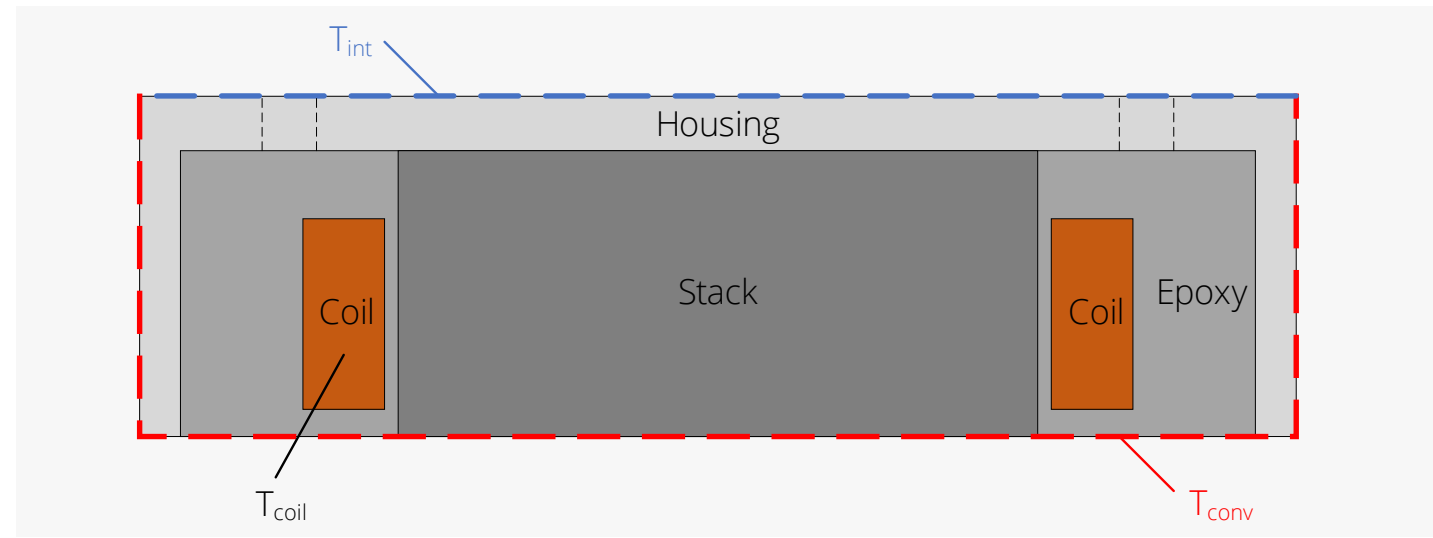

Chiron temperature definitions

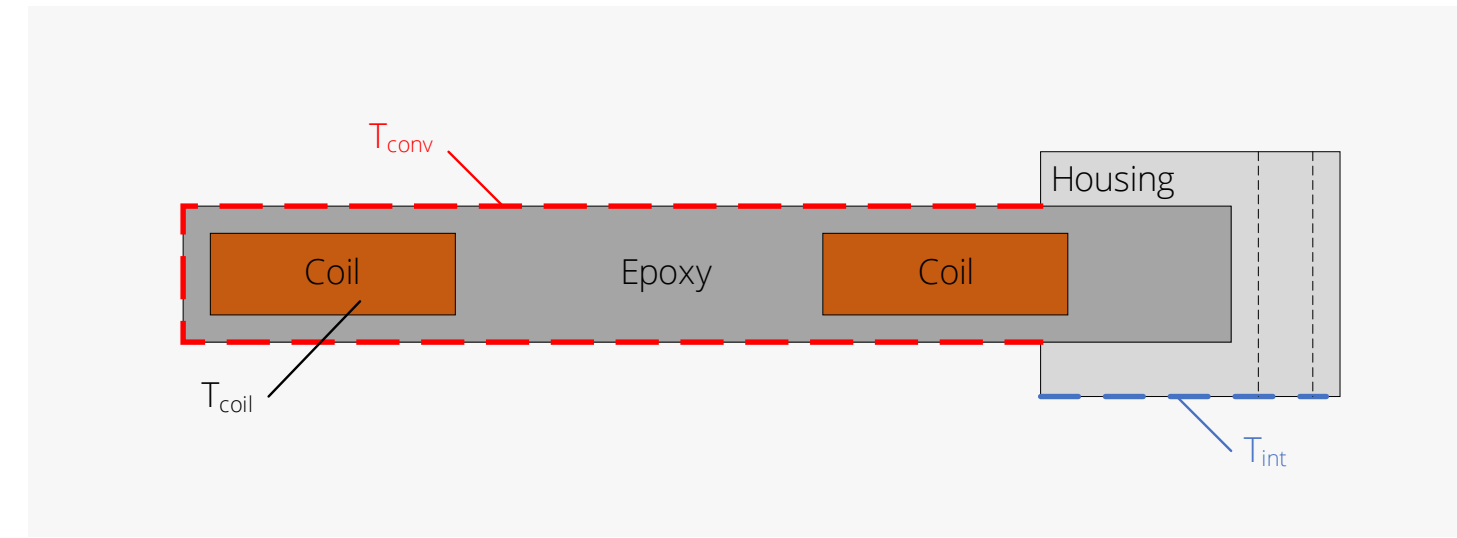

Phoenix / Gryphon temperature definitions

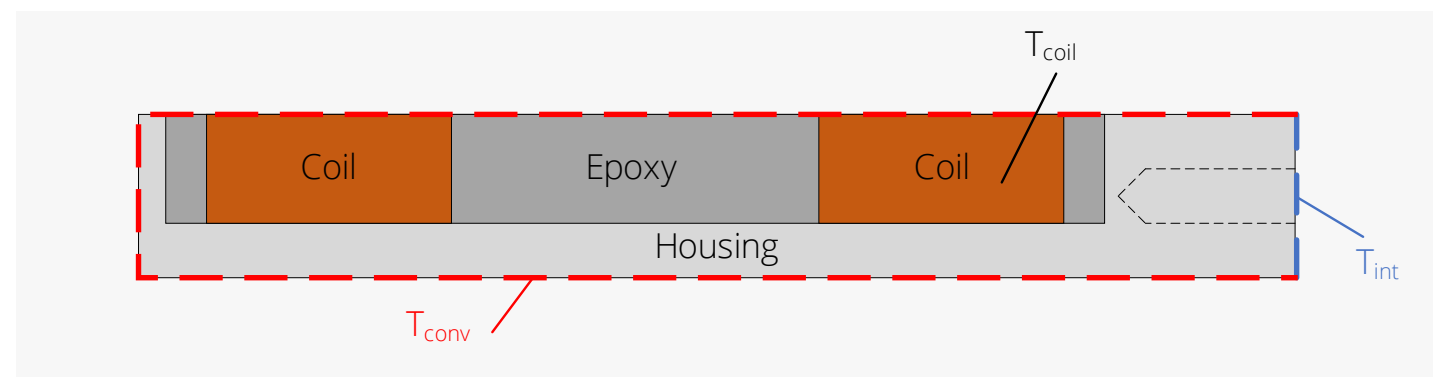

Iris-S temperature definitions

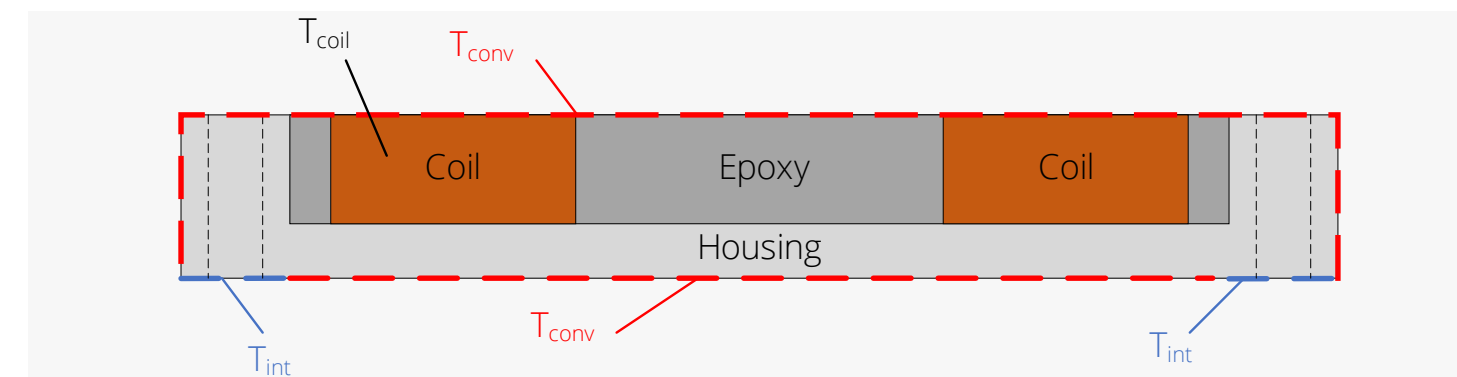

Iris-M/L temperature definitions

DEFINITIONS

Description	Equation	Unit	Remarks
Phase resistance at T_{coil}	$R_{ph} = R_{ph,20}(1+0.0039(T_{coil}-20))$	Ohm	
Force constant at no load	$K_{f,0} = \sqrt{3/2} K_{e,ll,p}$	N/A _{rms}	For Phoenix and Gryphon: $K_{f,0} = K_f$.
Continuous dissipation	$P_{d,c} = (T_{coil} - T_{int})/R_{th,i}$	W	Only copper losses are considered. This catalog considers $T_{int} = 20^\circ\text{C}$ and only heat dissipation towards the interface.
Peak dissipation	$P_{d,p} = C_{th} \alpha_T$	W	α_T is mentioned at the peak force specification. C_{th} is the heat capacitance of the coils only and not specified separately in the catalog.
Continuous rms current	$I_c = \min\left(\sqrt{\frac{P_{d,c}}{3R_{ph}}}, \frac{V_{dc}}{\sqrt{6}R_{ph}}\right)$	A _{rms}	Limited either by continuous dissipation or dc voltage and resistance or connector ratings (if applicable).
Peak rms current	$I_p = \min\left(\sqrt{\frac{P_{d,p}}{3R_{ph,20}}}, \frac{V_{dc}}{\sqrt{6}R_{ph,20}}\right)$	A _{rms}	Limited either by peak dissipation or dc voltage and resistance or connector ratings (if applicable).
Continuous force	$F_c = K_{f,c} I_c$	N	For Phoenix and Gryphon: $K_{f,c} = K_f$.
Peak force	$F_p = K_{f,p} I_p$	N	For Phoenix and Gryphon: $K_{f,p} = K_f$.
Steepness	$S = \frac{K_{f,0}^2}{3R_{ph,20}}$	N ² /W	For Phoenix and Gryphon: $K_{f,0} = K_f$.
Maximum velocity (F = 0)	$v_m = \frac{V_{dc}}{K_{e,ll,p}}$	m/s	Iron losses are not considered.
Maximum velocity (F = F _p)	$v_i = \left(\tau_p \sqrt{6\tau_p^2 K_{f,p}^2 V_{dc}^2 + 54\pi^2 (L_{ph}^2 I_p^2 V_{dc}^2 - 6L_{ph}^2 R_{ph,20}^2 I_p^4)} - 6\tau_p^2 K_{f,p} R_{ph,20} I_p\right) (2\tau_p^2 K_{f,p}^2 + 18\pi^2 L_{ph}^2 I_p^2)^{-1}$	m/s	For Phoenix and Gryphon: $K_{f,p} = K_f$. Iron losses are not considered.
Maximum velocity (F = F _c)	$v_n = \left(\tau_p \sqrt{6\tau_p^2 K_{f,c}^2 V_{dc}^2 + 54\pi^2 (L_{ph}^2 I_c^2 V_{dc}^2 - 6L_{ph}^2 R_{ph,100}^2 I_c^4)} - 6\tau_p^2 K_{f,c} R_{ph,100} I_c\right) (2\tau_p^2 K_{f,c}^2 + 18\pi^2 L_{ph}^2 I_c^2)^{-1}$	m/s	For Phoenix and Gryphon: $K_{f,c} = K_f$. Iron losses are not considered.

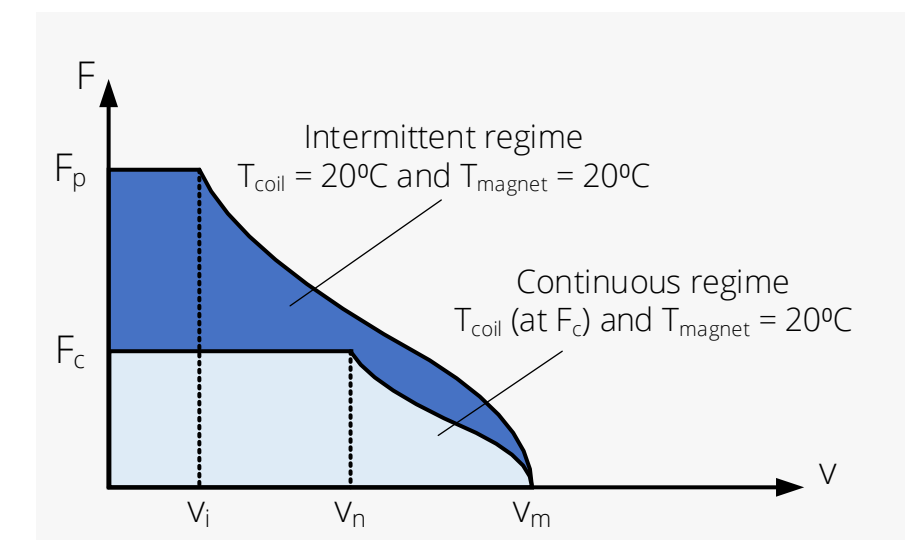

Force-velocity curves

CONTACT

Phone: +31 (0)40 2676200

E-mail: sales@prodrive-technologies.com

Web: www.prodrive-technologies.com

December 2023

The content of this catalog is subject to change without prior notice